

# RADIOGENSE

The ~~last~~<sup>first</sup> meter of Internet of Things



## Innovation

R6E is a reliable partner for Open Innovation about wireless and battery-less RFID sensor technologies



## Development

R6E develops added-value and customized solutions based on the paradigms of Internet of Things and Industry 4.0



## Deployment

R6E takes care of the installation and commissioning of I-IoT systems, plant and/or equipment at the customer's site.



# RADIO6ENSE's Genesis

> 20 years of research on RFID sensing



Laboratorio di  
Elettromagnetismo  
Pervasivo

**PIONEERING**

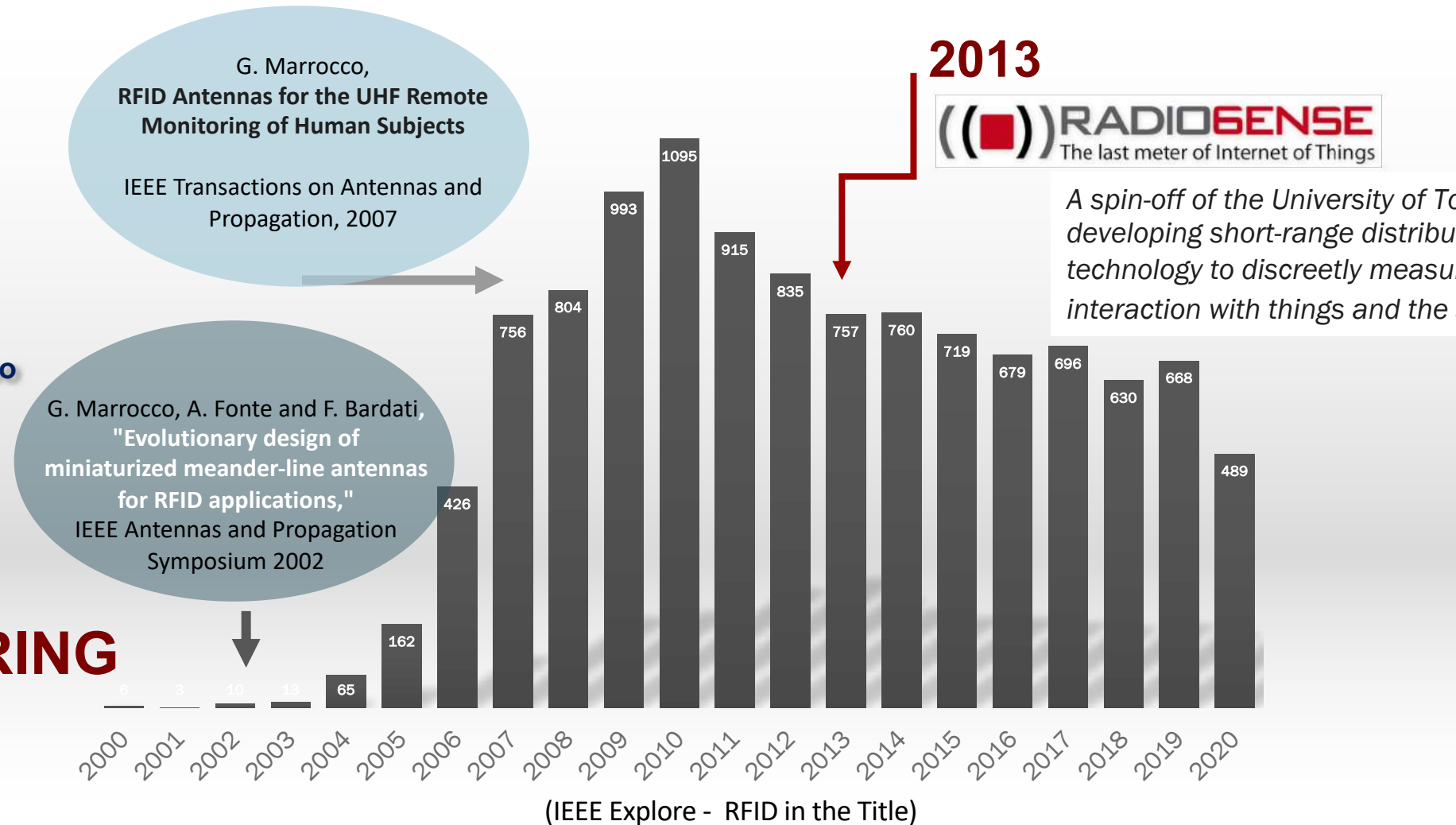

# Top 10: “RFID + Sensors” entries



(Source: Scopus, July 2023)

## Documents by author

Compare the document counts for up to 15 authors.

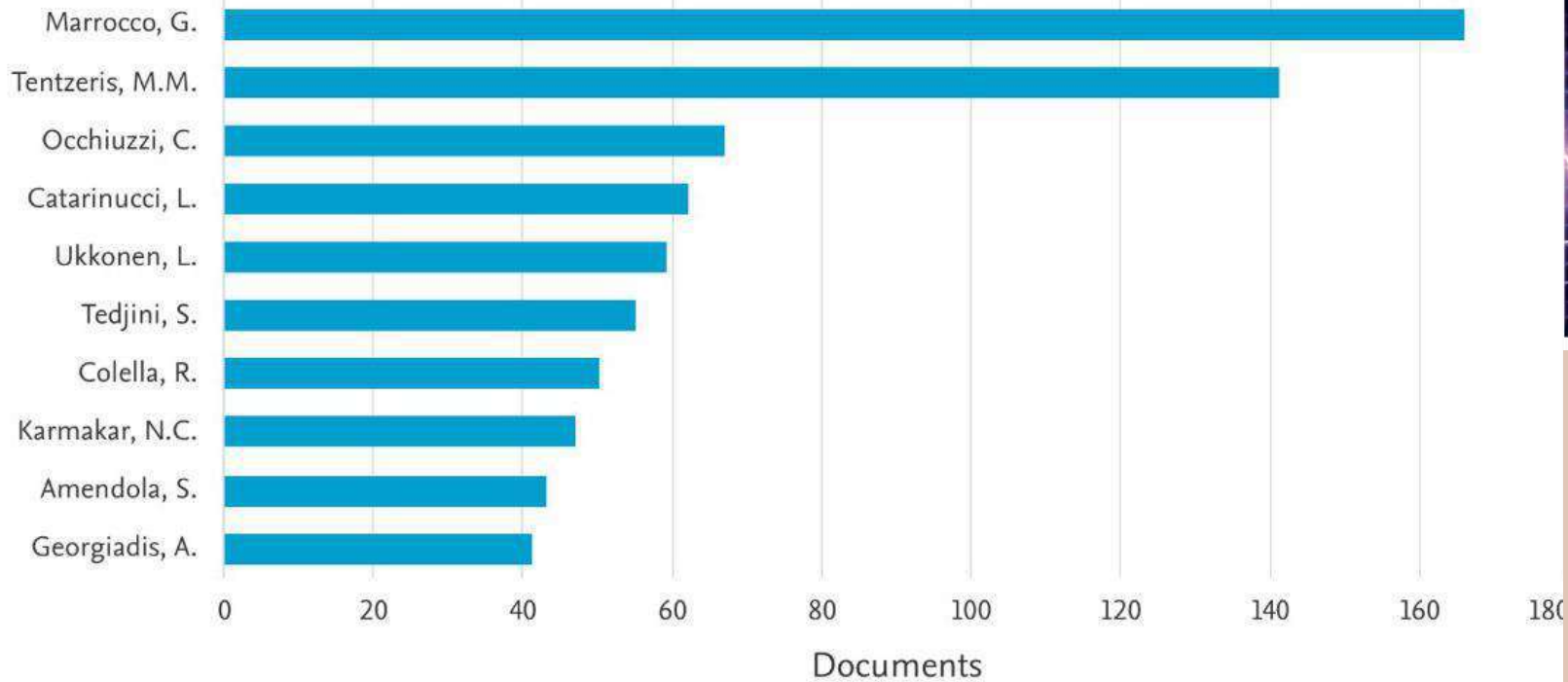

Sensors for Humans **Wearable, Epidermal, Implantable**  
Sensors for **Environment and Things**

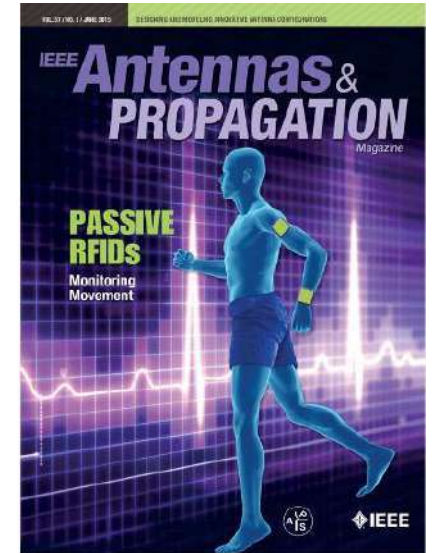

2015

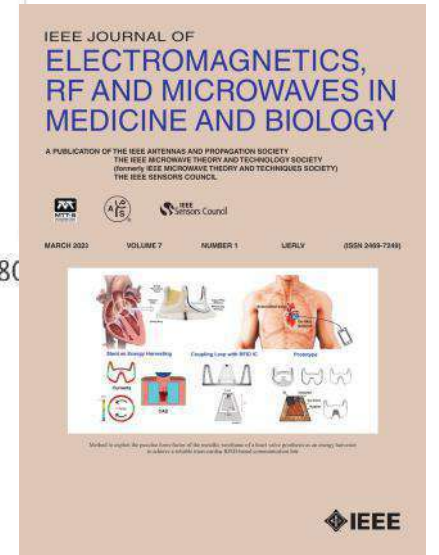

2023

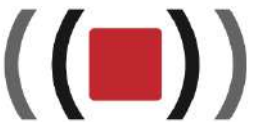

# The *virtuous* loop

*Academia & Industry*



RADIO6ENSE collaborates with the Pervasive Electromagnetics Lab of the University of Roma Tor Vergata, from which it draws new ideas to be transformed in industrial adding values.

Passion in research and innovation allows us to stay up to date on cutting-edge technologies delivering visionary solutions to our partners and customers

# The core team



## Educational Background

Medical Engineering (>60%)  
RF and Electronic Engineering  
Computer Science  
Telecommunications

> 60 % with PhD



**Gaetano Marrocco**  
PRESIDENT, PROFESSOR



**Cecilia Occhiuzzi**  
CEO, PROFESSOR



**Sara Amendola**  
EXECUTIVE MANAGER, PHD



**Stefano Caizzone**  
CO-FOUNDER, PHD



**Carolina Miozzi**  
System Engineer, PhD



**Nicola D'Uva**  
RF ENGINEER



**Adina B. Barba**  
RF ENGINEER



**Nicoletta Panunzio**  
Medical Eng., PhD Candidate



**Giulio M. Bianco**  
TEST ENGINEER, PHD



**Giorgio Piccardo**  
SOFTWARE ARCHITECT



**Fabio Angeletti**  
EMBEDDED SW ENGINEER, PHD

## Academic & Industrial Partnership

Cyber-Security Engineers  
Mechanical Engineers  
Data Scientist  
Chemistry Departments  
Mechanics



**Tatiana Ozhogina**  
ADMINISTRATIVE STAFF



**Federica Naccarata**  
Medical Engineer, PhD Intern



**Francesca Nanni**  
Medical Eng., PhD Intern



**Alessio Mostaccio**  
RF ENGINEER, PHD STUDENT



**Francesco Lestini**  
RF ENGINEER, PhD Intern



**Giulio Tufi**  
INTERN

## Professional Internships

- Master Students
- Industrial PhD

# Industry 4.0 Applications

R6E is a pioneer in the deployment of industrial RFID sensor networks

---



## MANUFACTURING

Cold and Hot Chain monitoring, Predictive Maintenance of Industrial machinery



## AUTOMOTIVE

Tire Manufacturing & Test, Distributed Temperature diagnostics for plants and race cars



## FOOD

Smart Packaging for monitoring food ripening, Plastic waste management for the circular economy



## HEALTHCARE

Pharma packaging for quality control and safety, E-Health and Digital Transformation of biomedical devices

# Customers & Partners

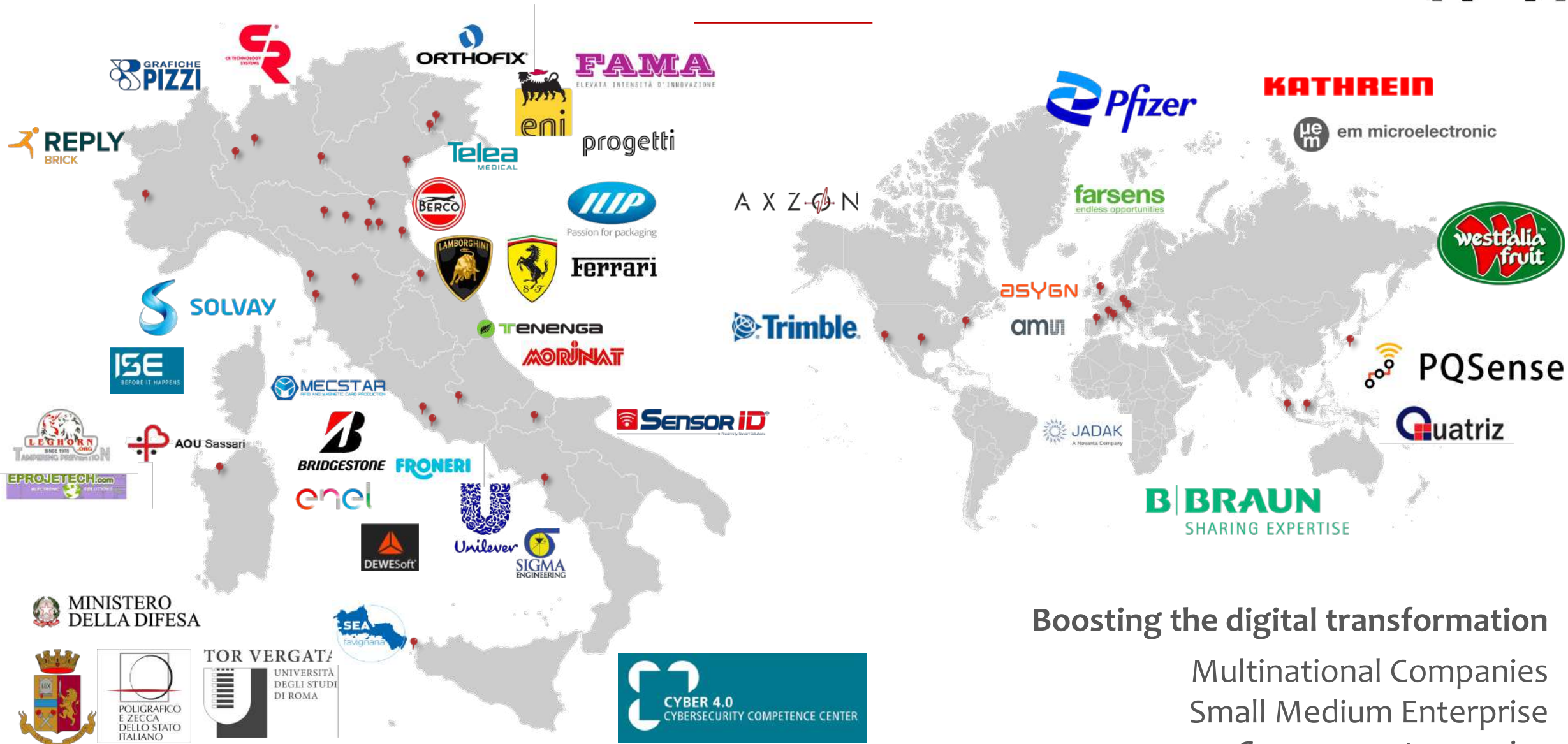

Boosting the digital transformation

Multinational Companies

Small Medium Enterprise

Government agencies

# Our Model



## Open Innovation Partner

Adding-value technology development  
TRL fast rising



Leveraging  
Research  
Outcome

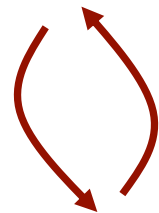

Inspiring  
Fundamental  
Research

## Customer Challenge

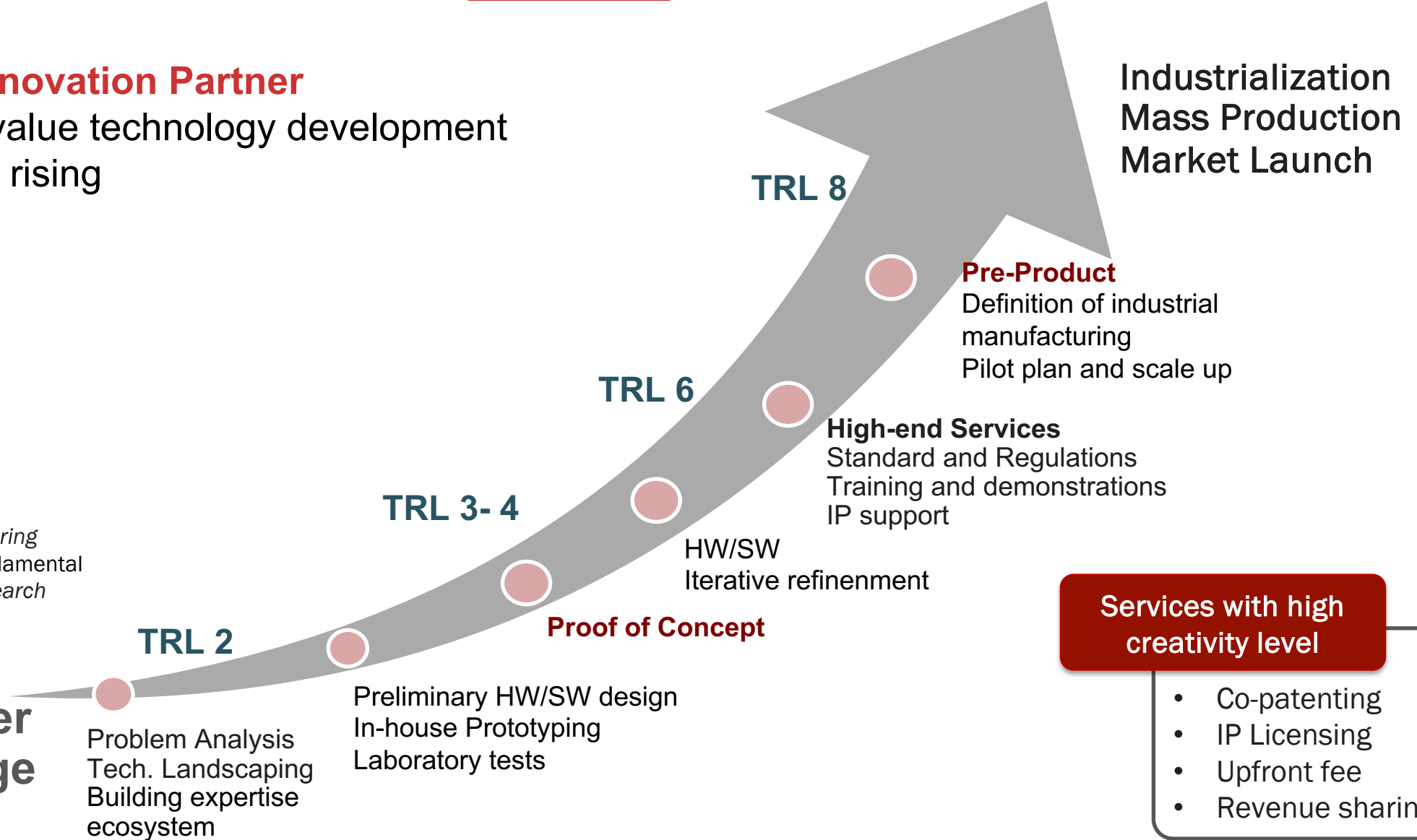

### Services with high creativity level

- Co-patenting
- IP Licensing
- Upfront fee
- Revenue sharing



# Our I-**IoT** Ecosystem

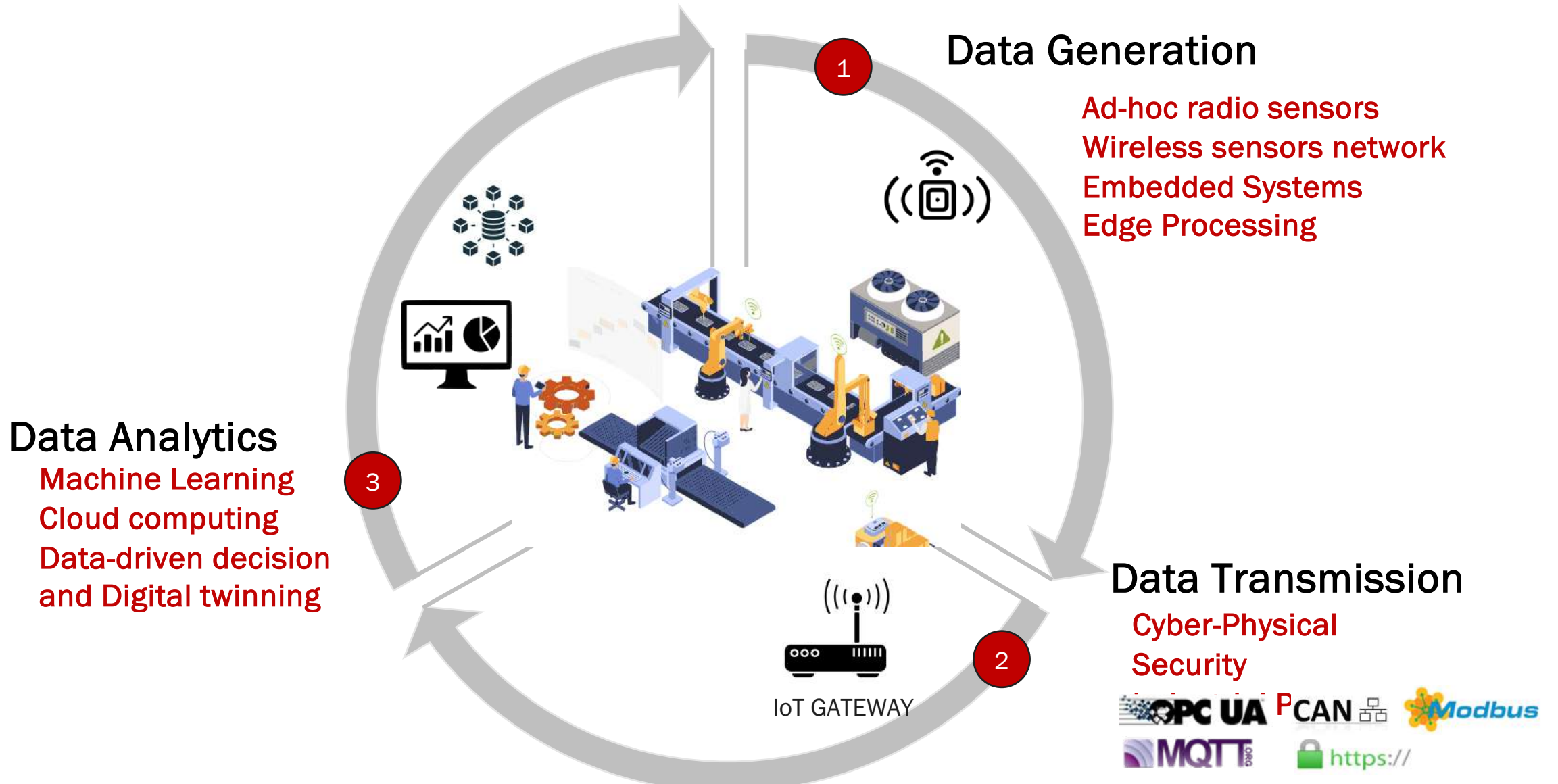

# The Physical Layer



Enabling a unprecedented level of wireless sensing

*From Micro....*

*...to Macro Scale*

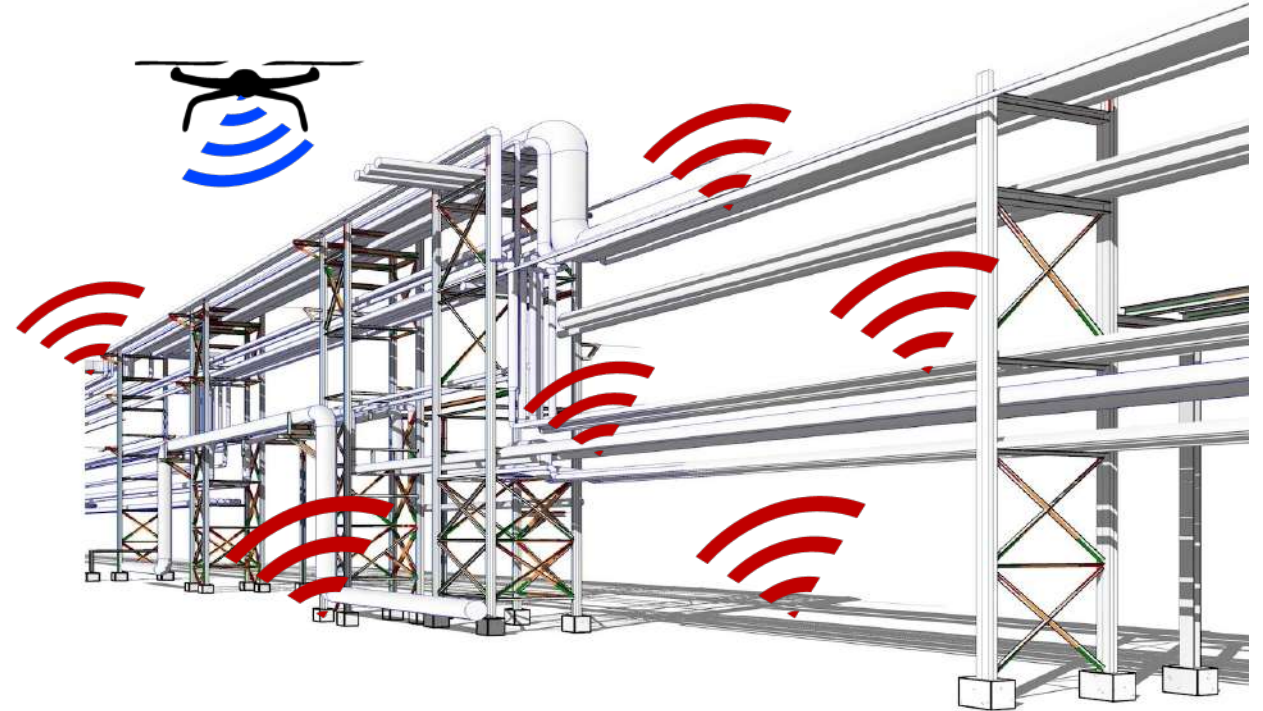

**Battery-less embedded sensors**  
*where no other sensing device could fit into*

**Multiple points distributed on large areas**  
*zero-power, no-wires, re-configurability*

# Unusual RFID sensors



Enabling a unprecedented level of wireless sensing

From Micro....

...to Macro Scale

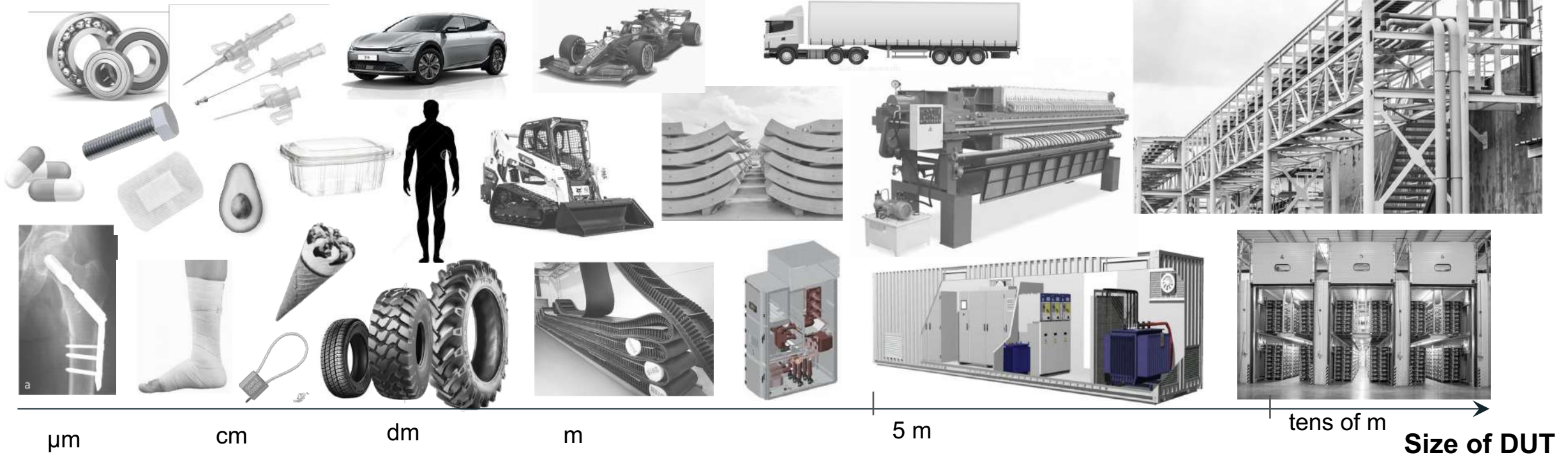

Real “things” empowered by RFID sensors (the *first* meter of IoT)

# Unusual RFID sensors



Enabling a unprecedented level of wireless sensing

*From Micro....*

*...to Macro Scale*

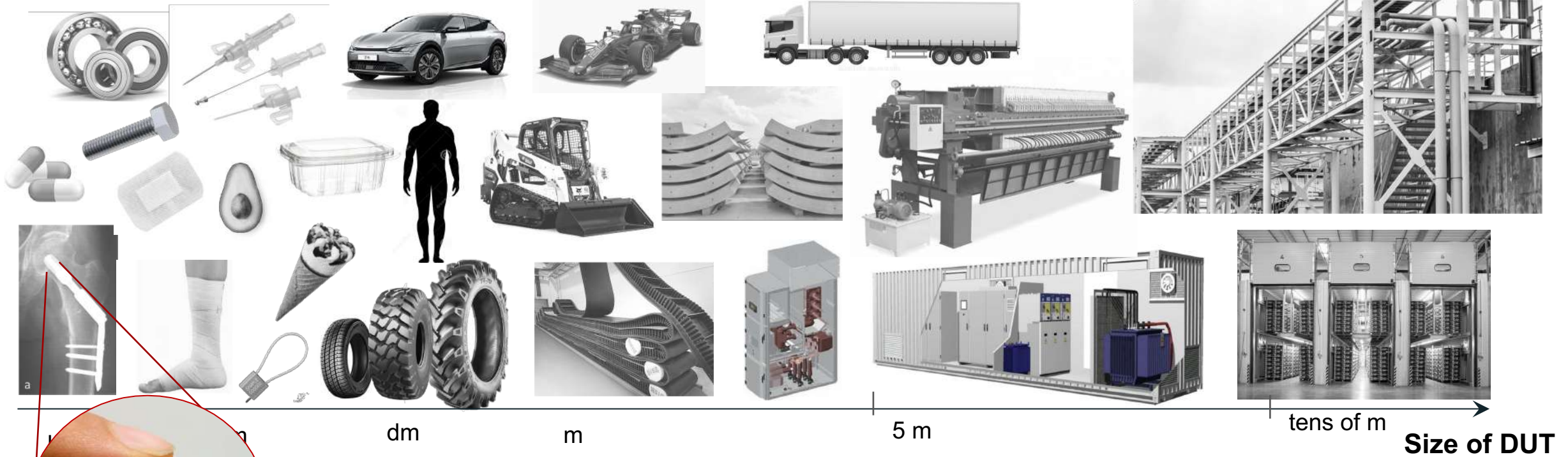

**Implantable medical  
devices**

# Unusual RFID sensors



Enabling a unprecedented level of wireless sensing

*From Micro....*

*...to Macro Scale*



**Plasters, Dressings,  
Bandages**

# Unusual RFID sensors



Enabling a unprecedented level of wireless sensing

*From Micro....*

*...to Macro Scale*

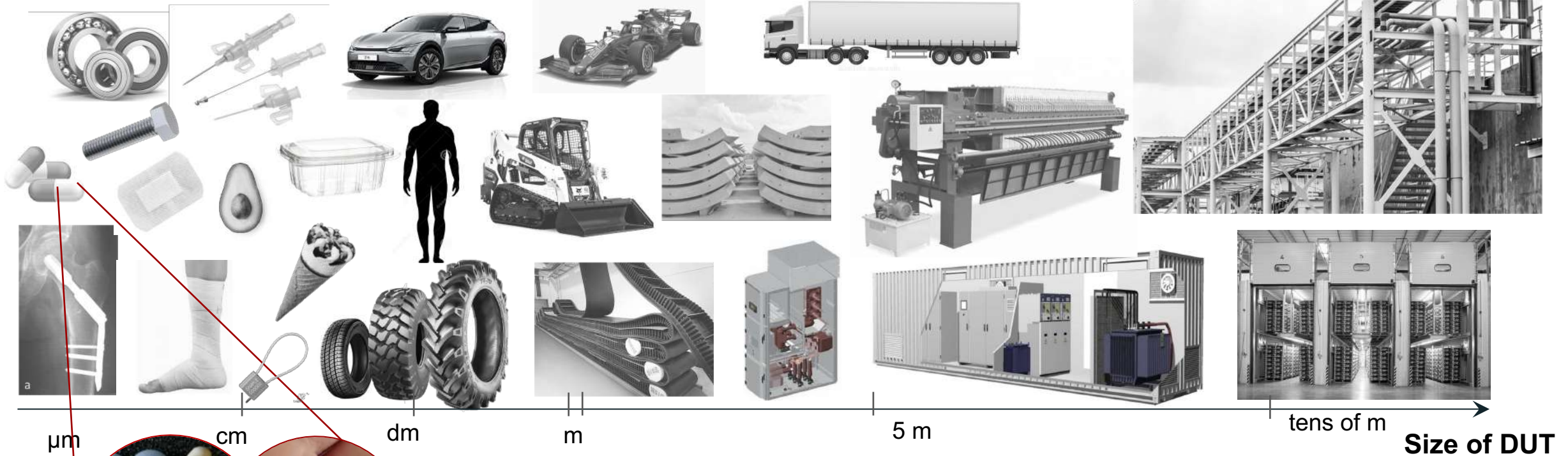

**Pharmaceuticals**

# Unusual RFID sensors



Enabling a unprecedented level of wireless sensing

*From Micro....*

*...to Macro Scale*

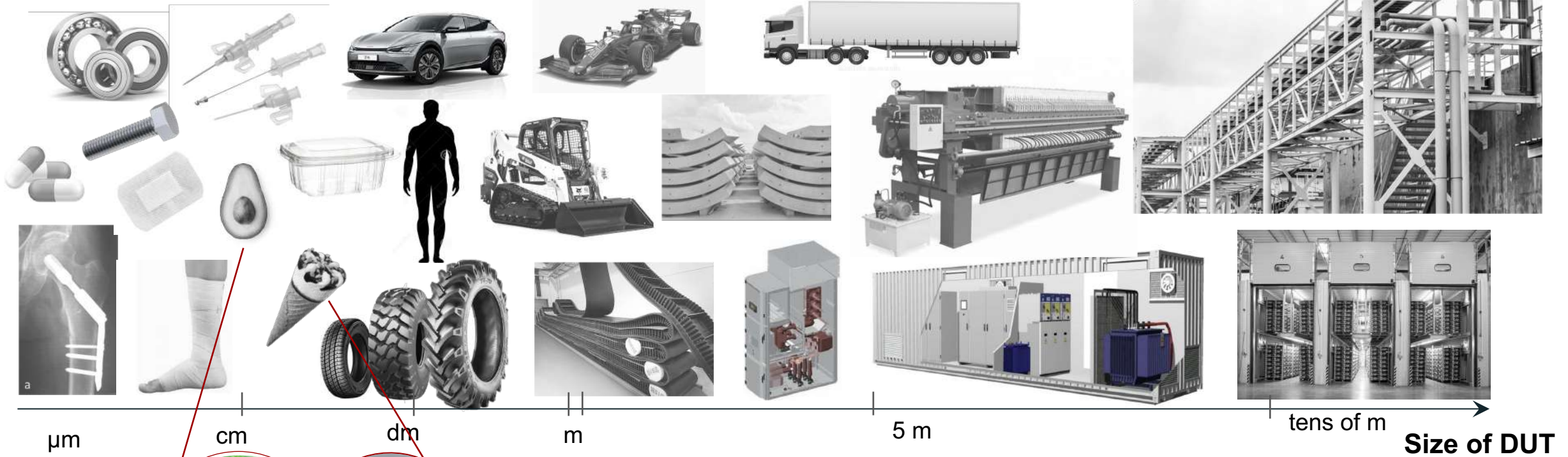

**Food & Packaging**

# Unusual RFID sensors



Enabling a unprecedented level of wireless sensing

*From Micro....*

*...to Macro Scale*

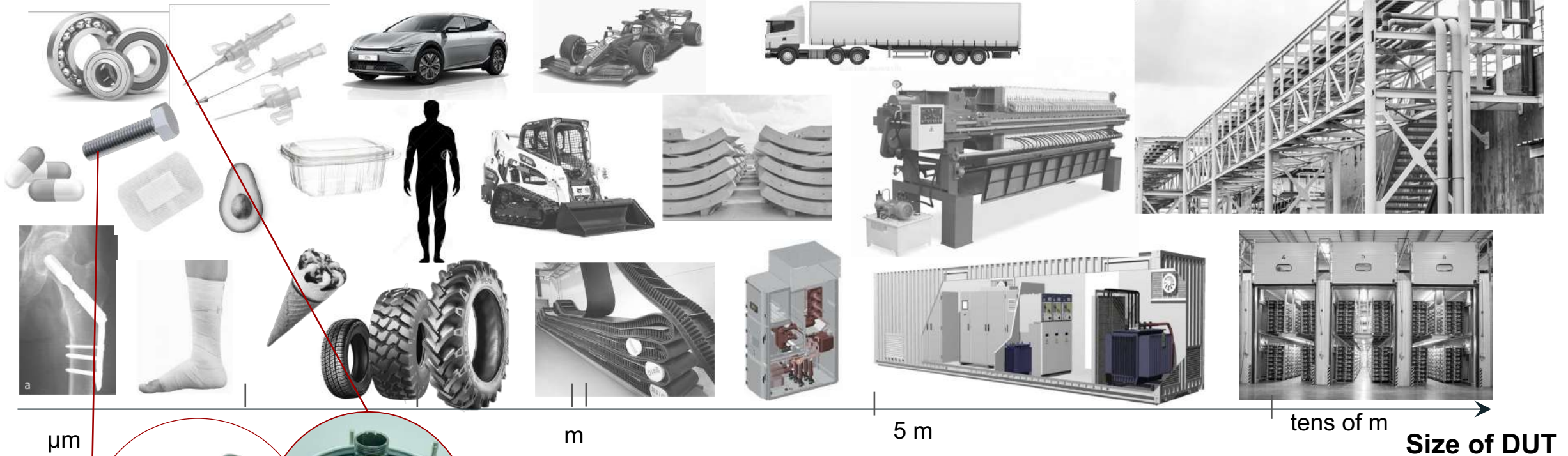

**Screws, Bearings and motors**



# Unusual RFID sensors



Enabling a unprecedented level of wireless sensing

*From Micro....*

*...to Macro Scale*

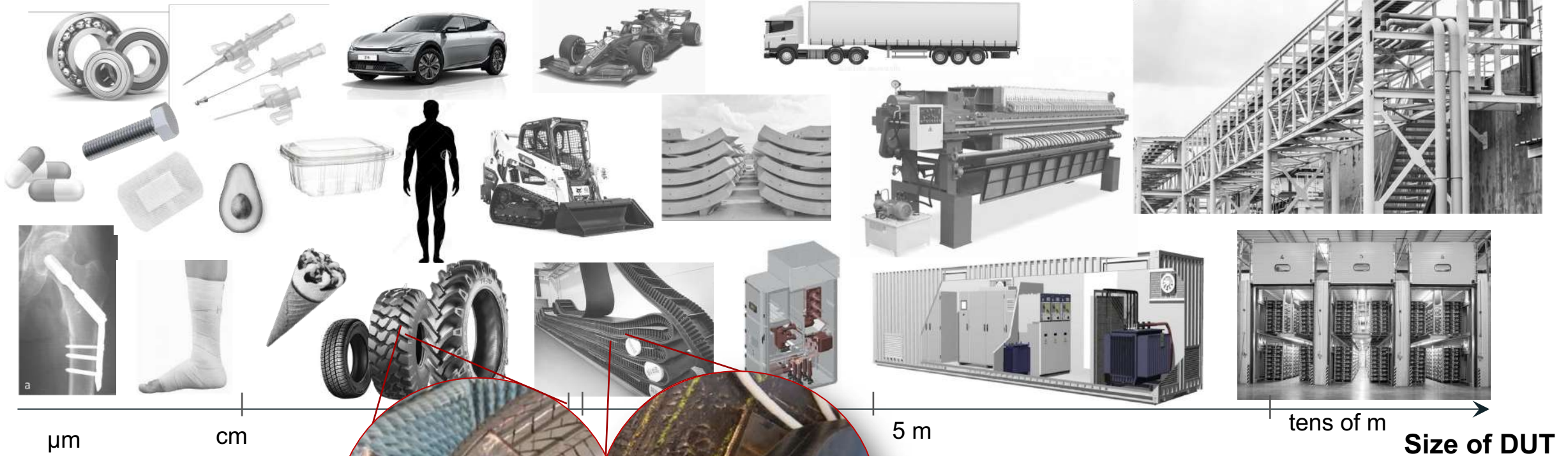

**Rubbers (Tyres, Conveyors)  
Composite Polymers**

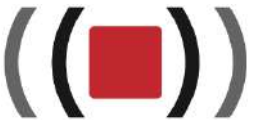

# Unusual RFID sensors

Enabling a unprecedented level of wireless sensing

*From Micro....*

*...to Macro Scale*



$\mu\text{m}$

c

tens of m

Size of DUT

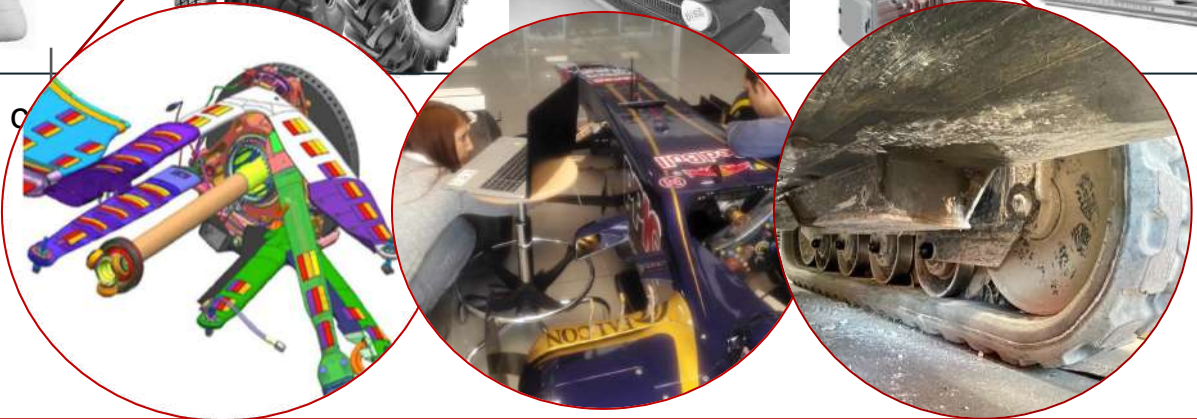

**Vehicles**  
(racing, industrial, passenger, truck)

# Unusual RFID sensors

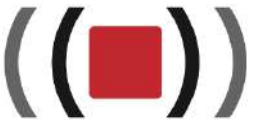

Enabling a unprecedented level of wireless sensing

*From Micro....*

*...to Macro Scale*

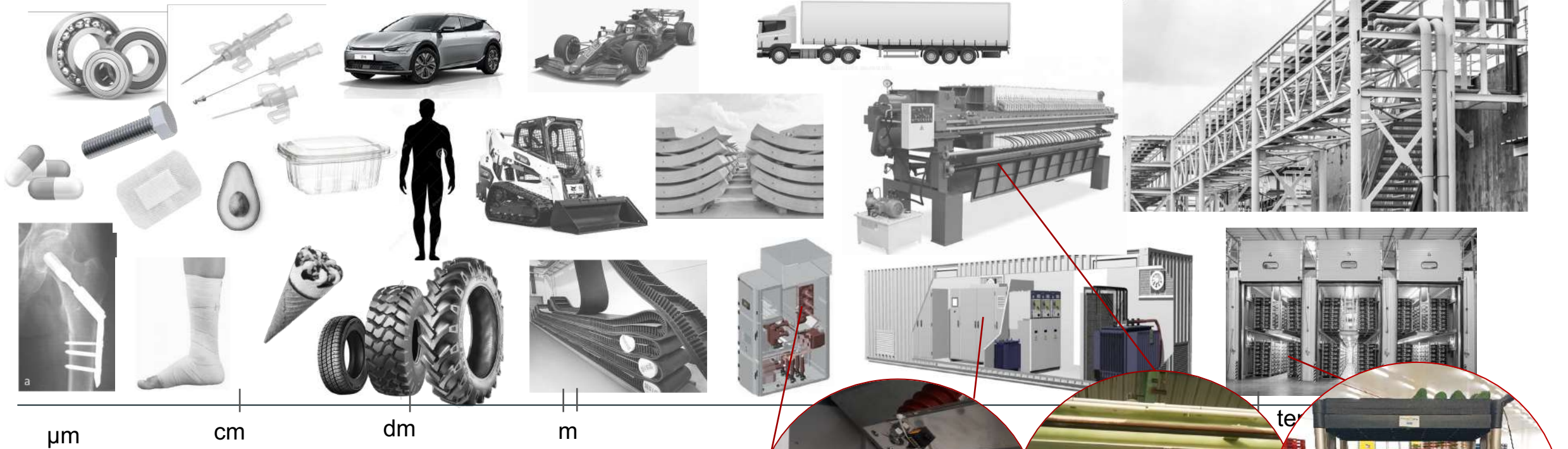

**Industrial Plants  
Chemical, Electrical Oil&Gas  
Infrastructure**

# Unusual RFID sensors



Enabling a unprecedented level of wireless sensing

**From Micro....**

**...to Macro Scale**

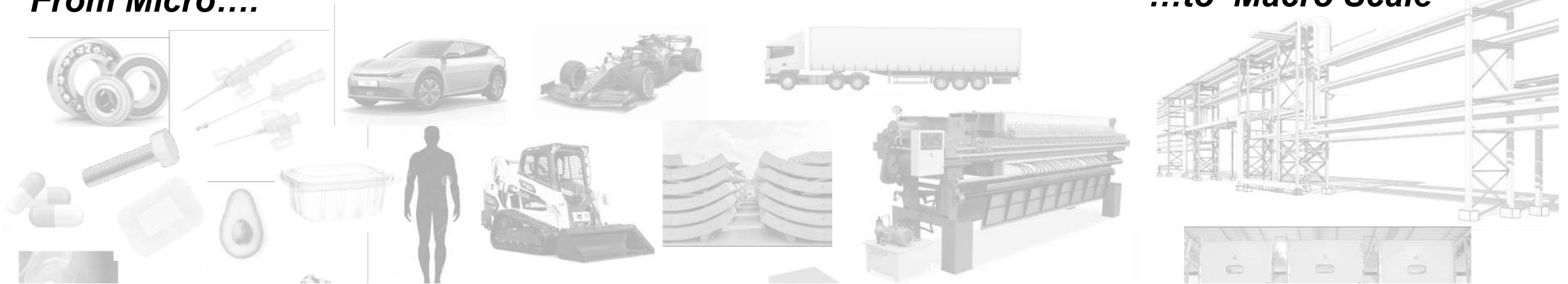

**Keeping electronics as simple as possible, Moving Intelligence “outside” the physical words**

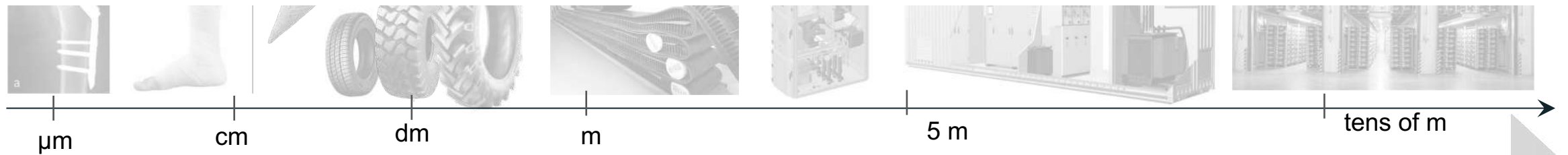

## COMPLEXITY & CHALLENGES

- Tag Design
- Durability
- Radio Coverage
- Cyber-Security
- Data Analytics**
- Integration
- Miniaturization
- Materials (bio!)
- Link Reliability
- System Integration

# The application Layer

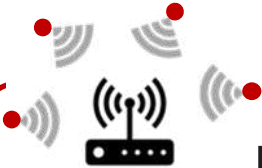

RadioScan Software Tool((■))

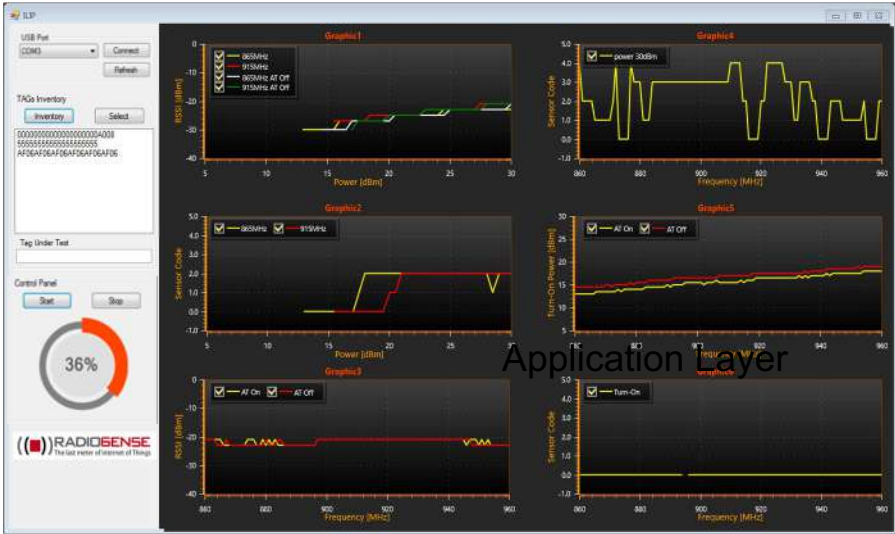

Application Layer

- Real-time reading of multi-EM indicators from a multitude of sensors
- GUI for Data visualization
- Low-level preprocessing of raw EM data
- Data analytics (option)
- Streaming data to upper layers of IoT platform
- Highly customizable

Communication Protocol



DATA ANALYTICS

Machine Learning

DEWESoft™  
measurement innovation

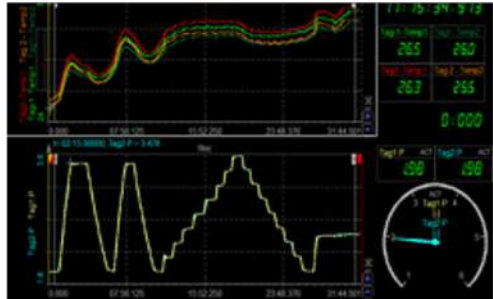

ThingsBoard

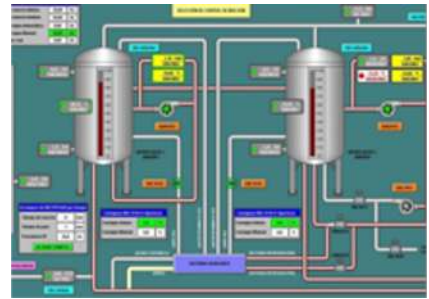

- Database
- Local Data Acquisition Software
- Web Dashboard
- Cloud-based analytics service (e.g. Power BI)
- Custom on demand

Edge Computing ←

→ Cloud Computing

# RFID sensors for Industry 4.0

*Real Use Cases*

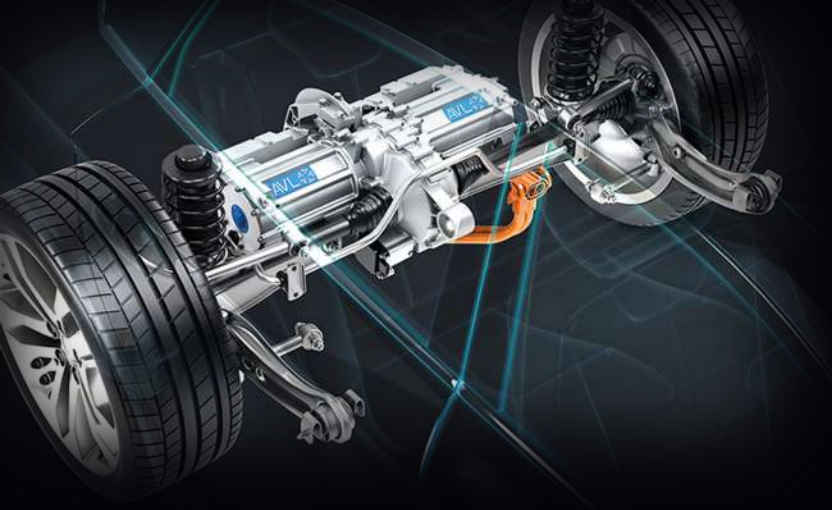

# AUTOMOTIVE



# Tyre Manufacturing



Green Tyre



Curing press machine

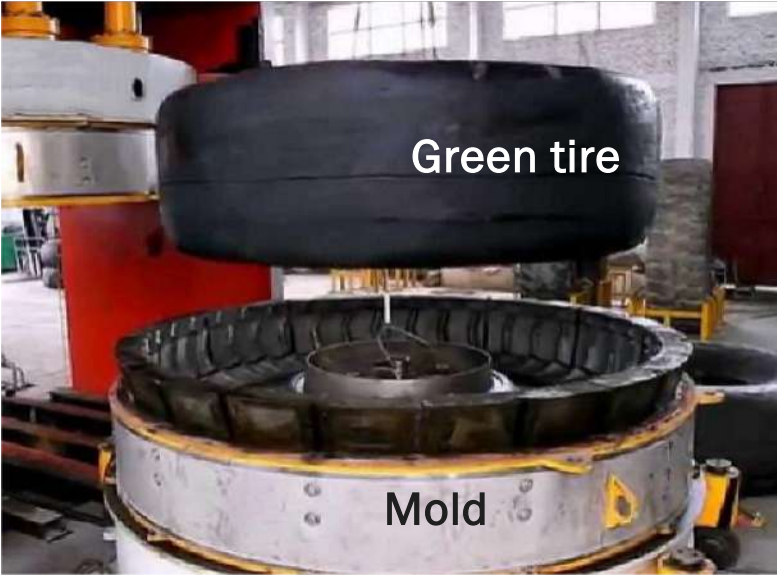

Laboratory Mockup

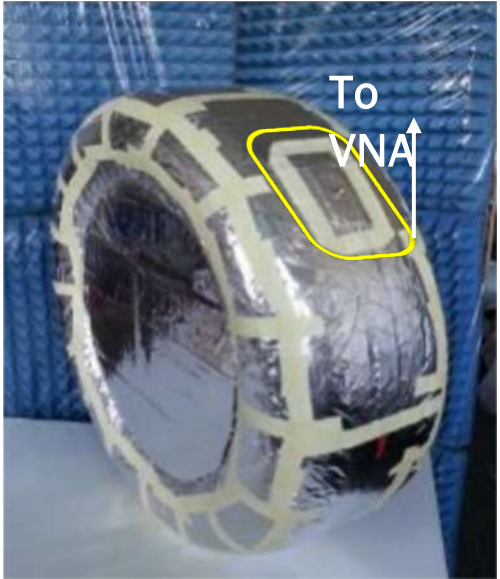

Near Field Two-Port Modeling

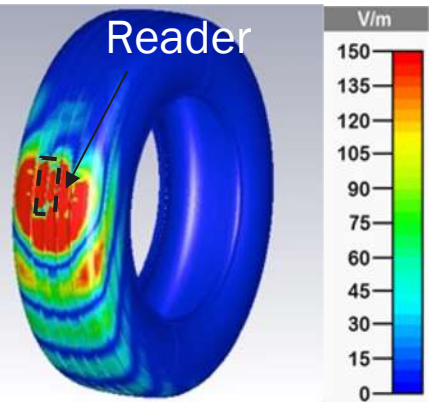
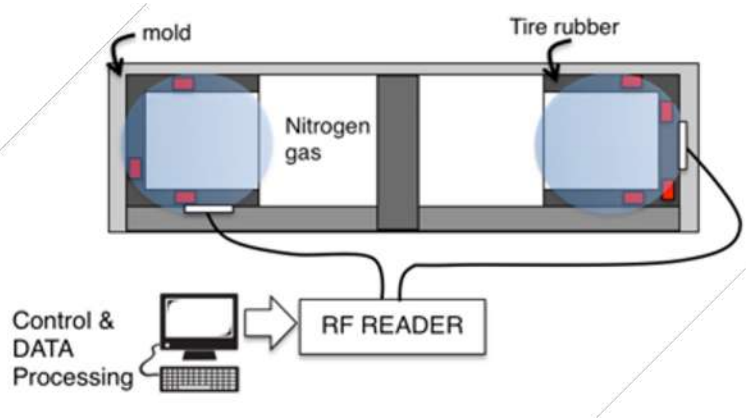

Link Budget

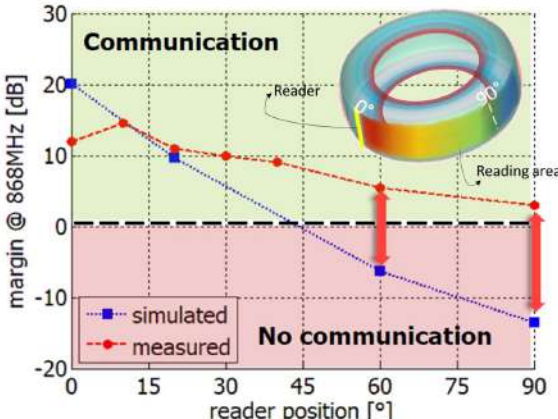

Temperature Monitor

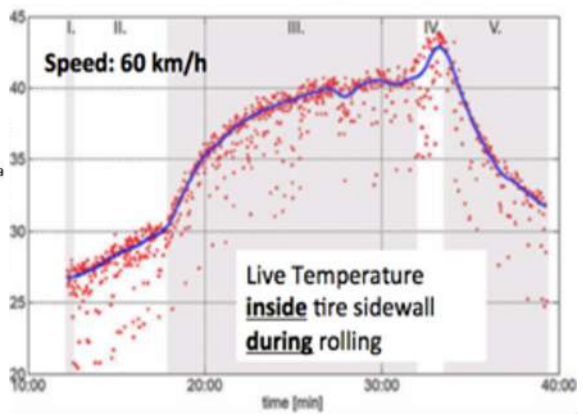



# Monitoring Undercarriage



## Smart Roller



Roller **Temperature Monitoring**

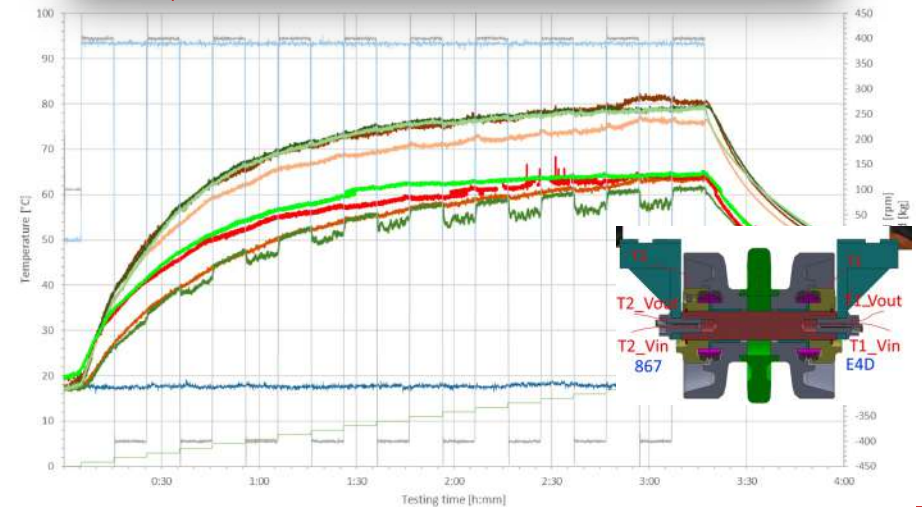
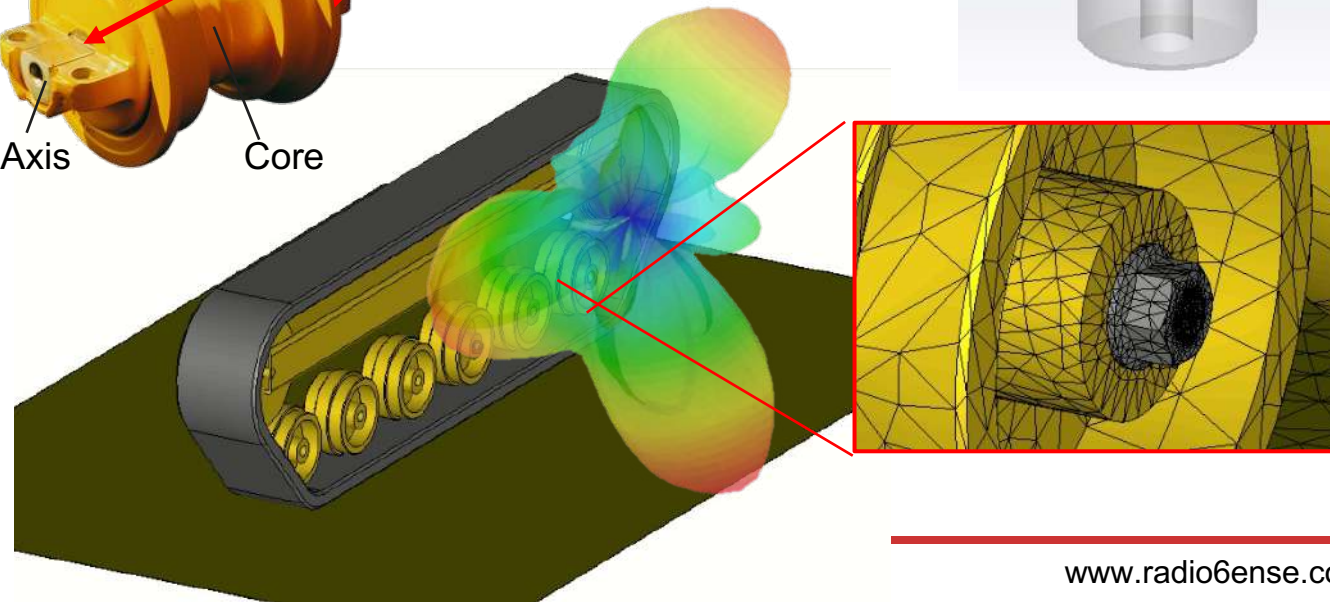
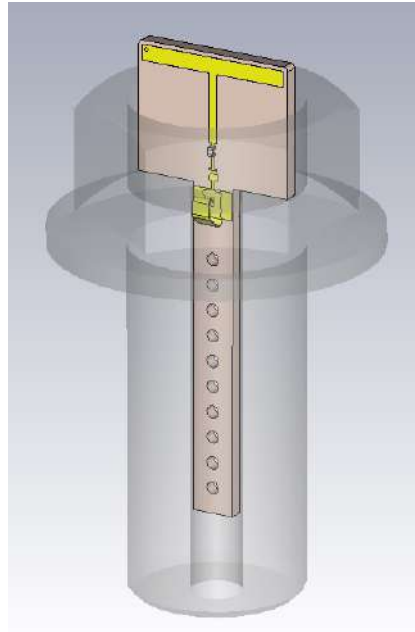
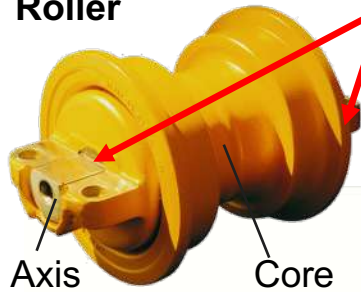

# On-vehicle PoC

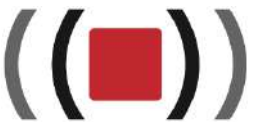

# On-vehicle PoC

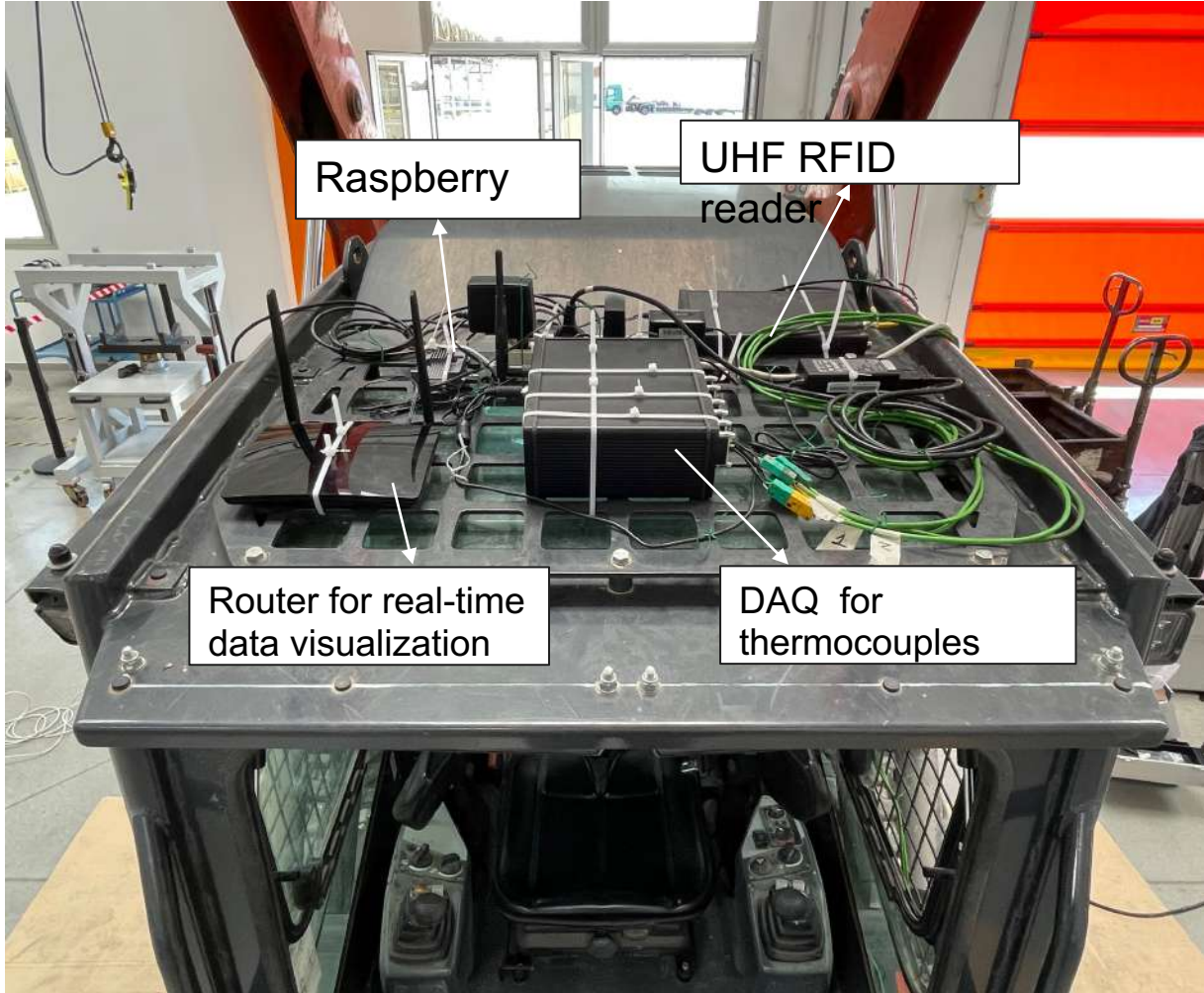
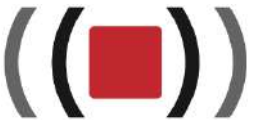



# F1 Racing



## T-Logger to monitor vehicle Components

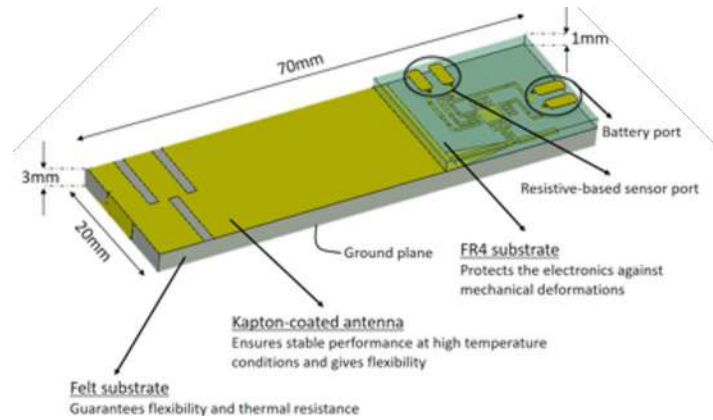
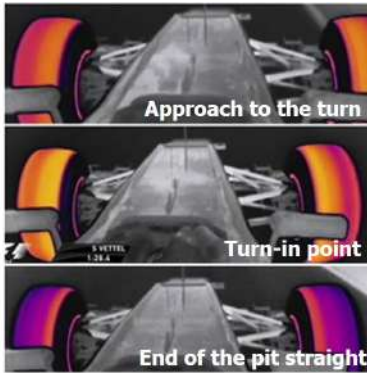

### Therma-tape replacement...

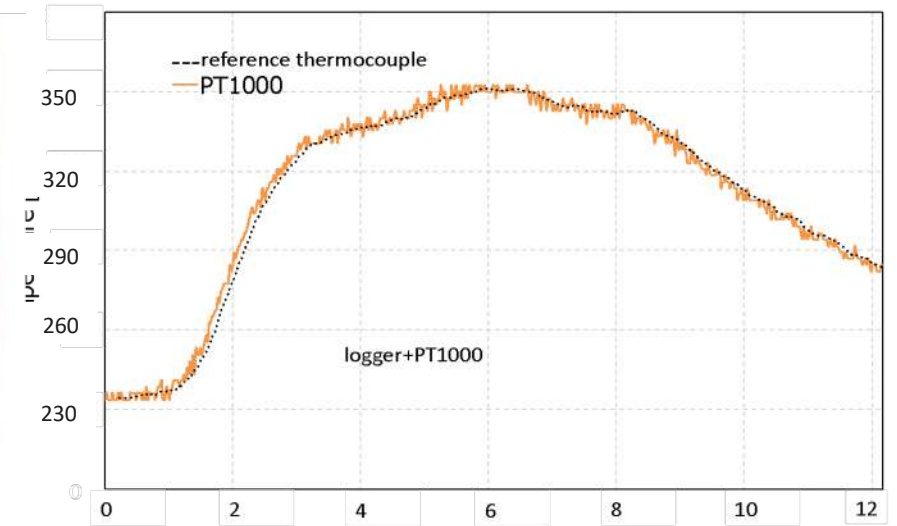
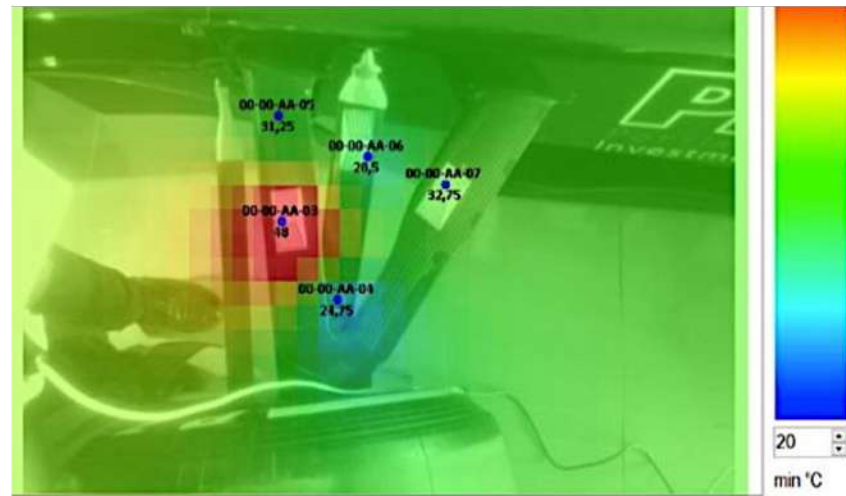

# Bearing Temperature Monitoring

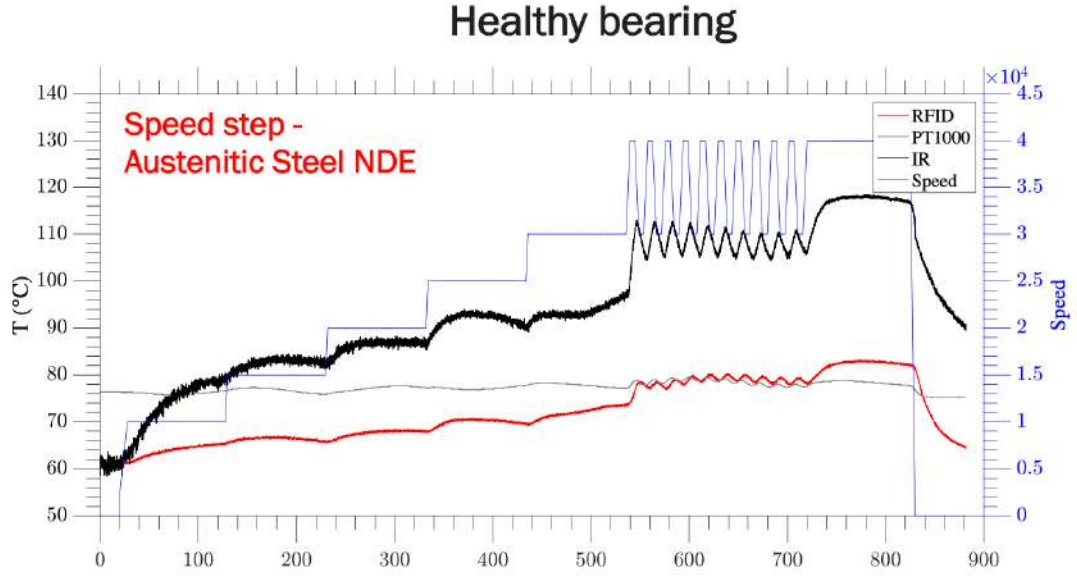
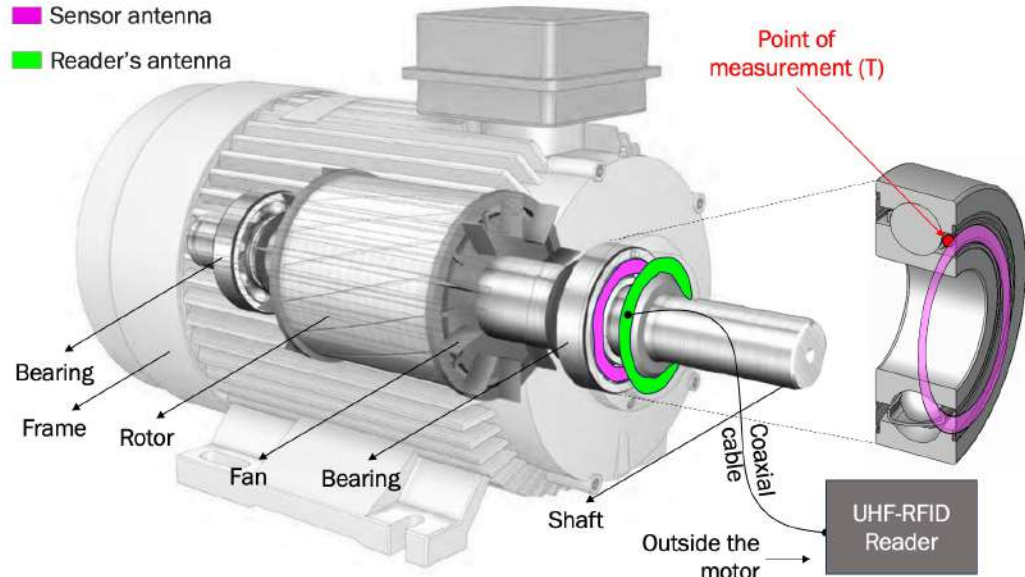

E-field Simulations

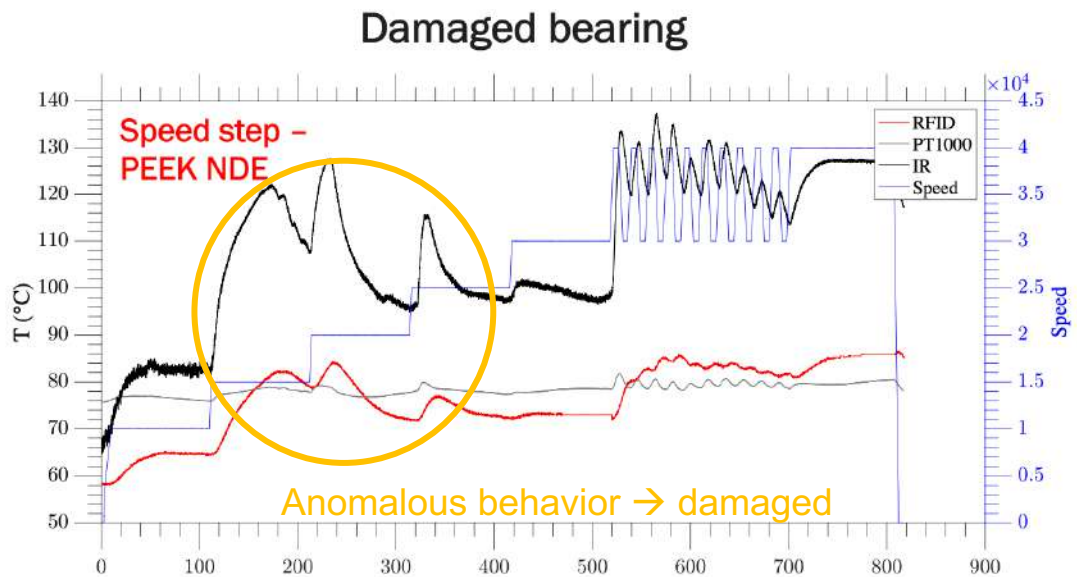
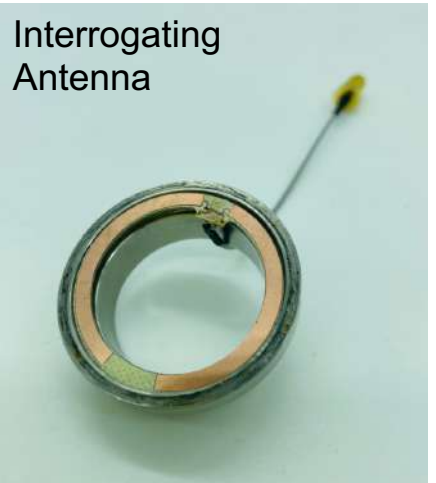
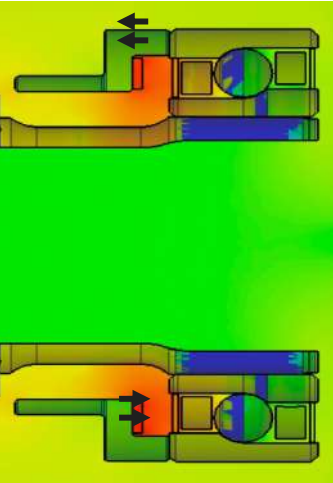

# RFID-powered Interconnected Vehicles



Off-vehicle platform

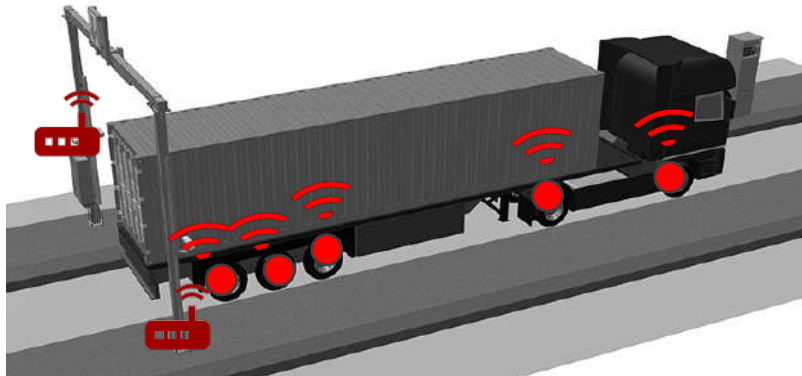

On-vehicle platform

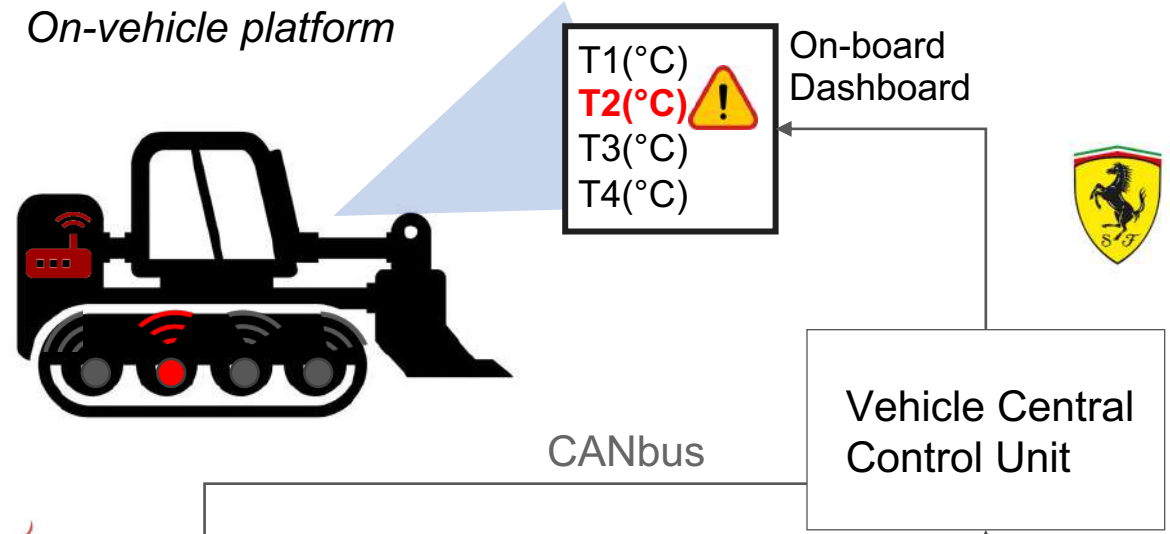

Ferrari

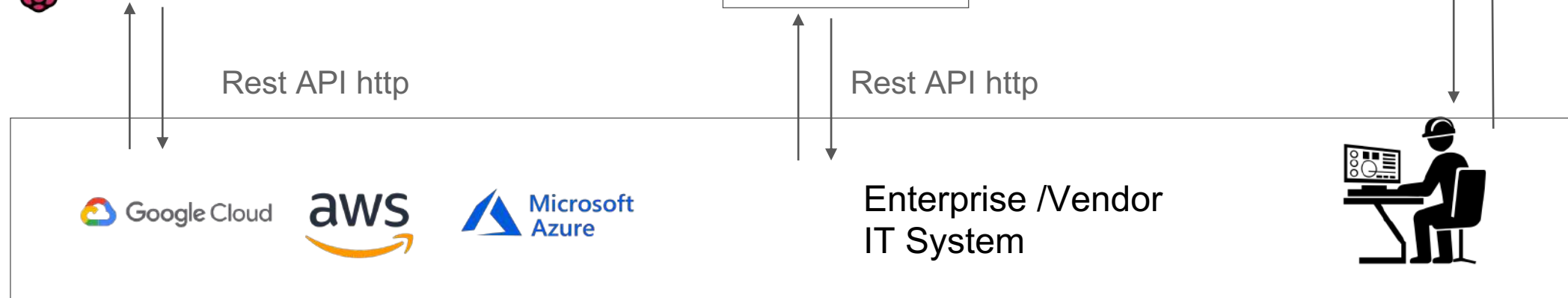
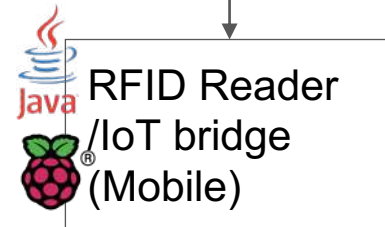
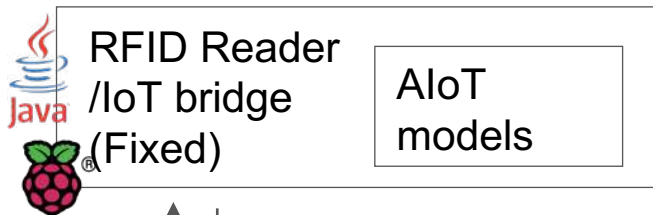

# MANUFACTURING



# Chemical Plants



## Predictive Maintenance of Filter Press

Frequent failure of Membranes trigger cascade damaging process up to complete stop

Anomalous flows of hot fluid insides the inflating hoses might predict malfunctioning

BUT: **!** Hundreds of tubes  
**!!** Frequently replaced

## RFID-based Predictive System





# Chemical Plants

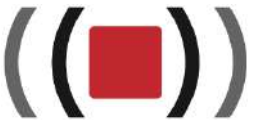

## The Electromagnetic Nightmare



## CHALLENGES

- Metals, vapours, silica powders (scattering, reflection, losses)
- EM noise (engine)
- Durability vs highly corrosive ambient
- **RF coverage** of large machinery (>15m) , moving parts and variables tube filling
- **> 150 points of measurements**
- Old Plant No modifications
- Data Analytics: find predictors!

# Chemical Plants

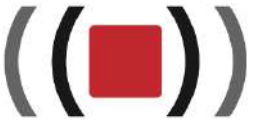

Pilot System (January 2021)

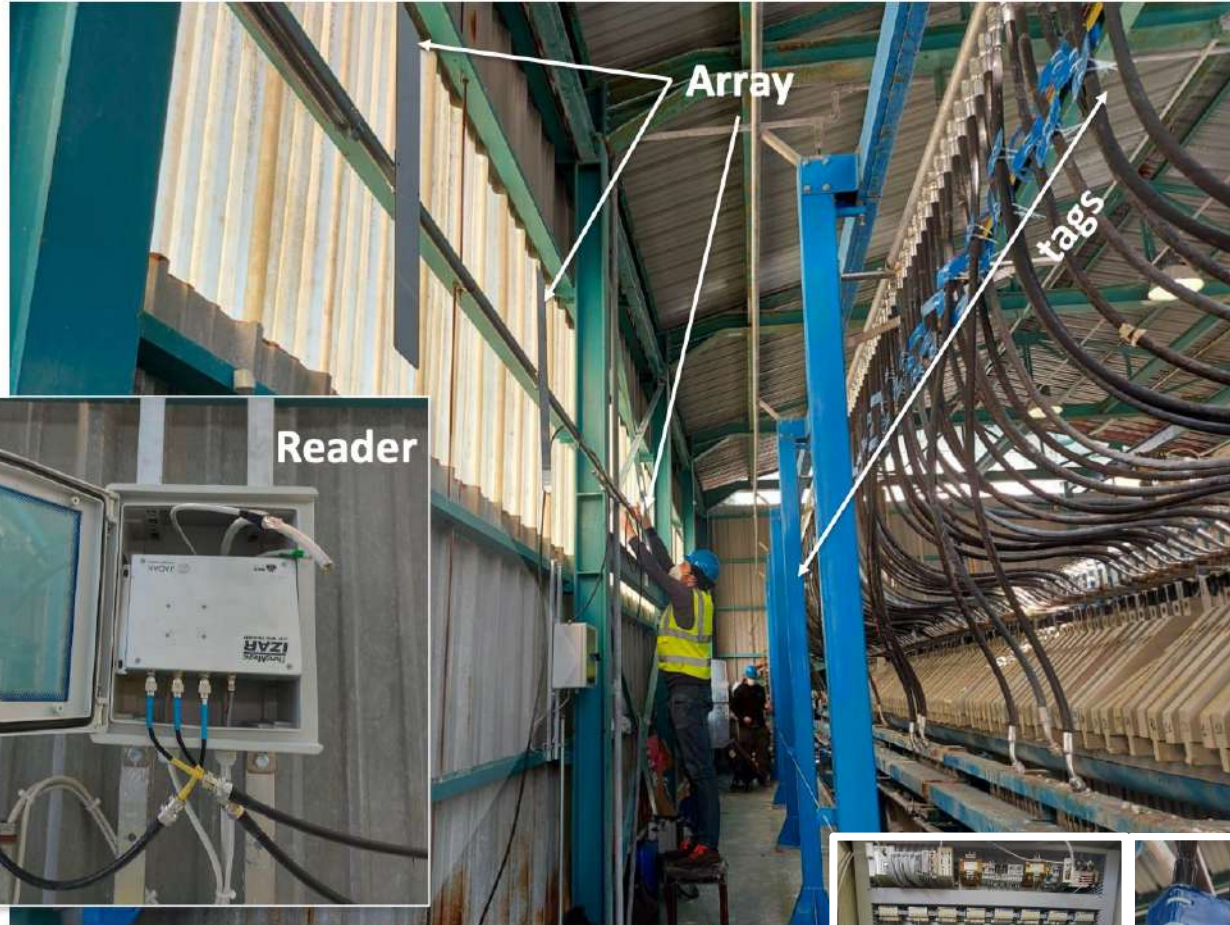

### RADIO-COVERAGE ON A WIDE AREA

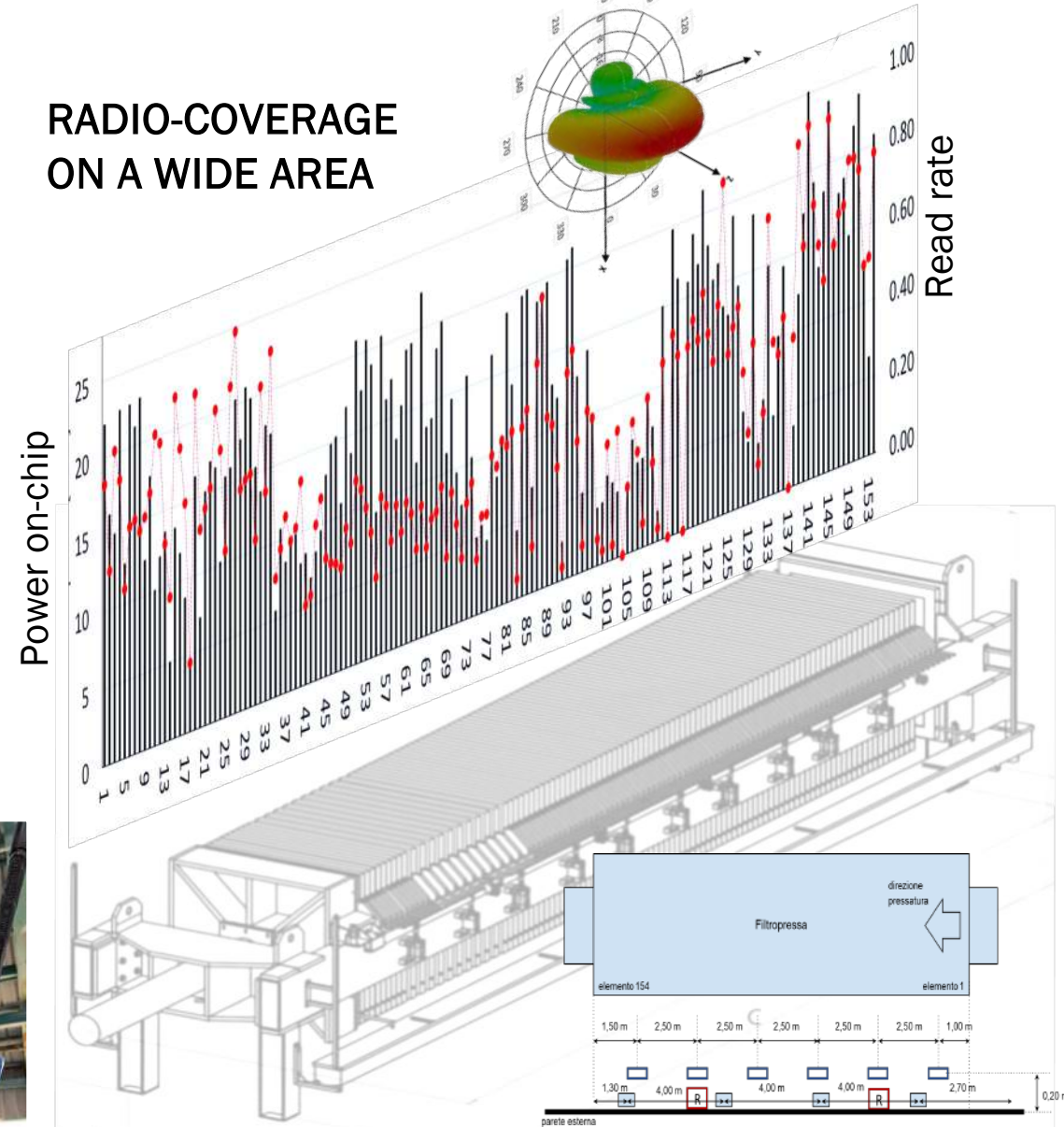

- Zero-downtime installation
  - **Retrofit** (no changes of the existing machinery neither of the hoses)
- “Transparent”** monitoring layer

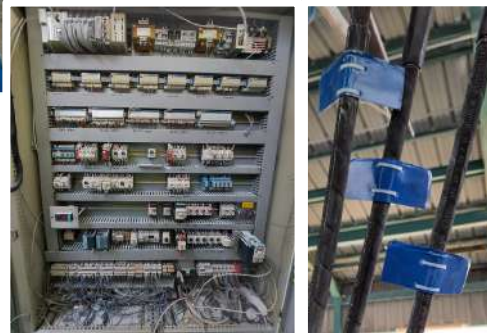

# The platform

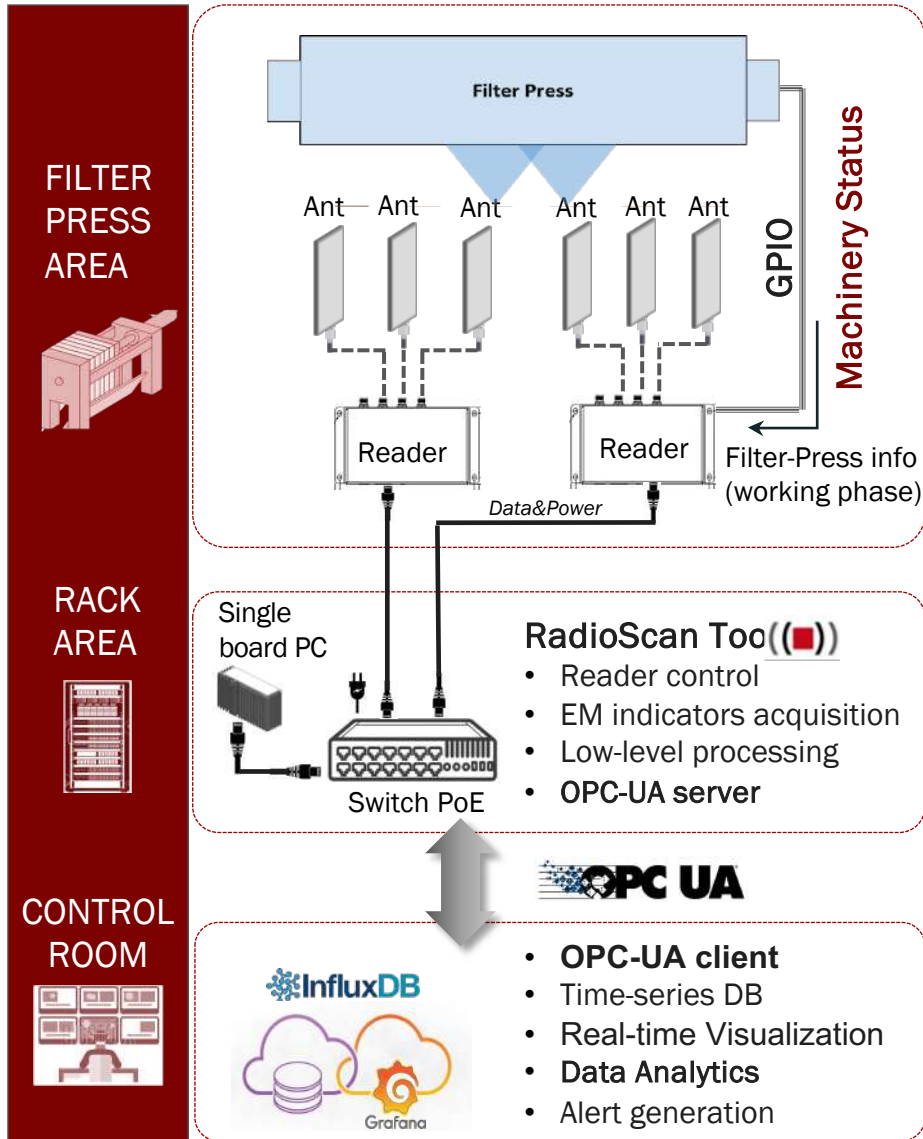

## Web-Dashboard

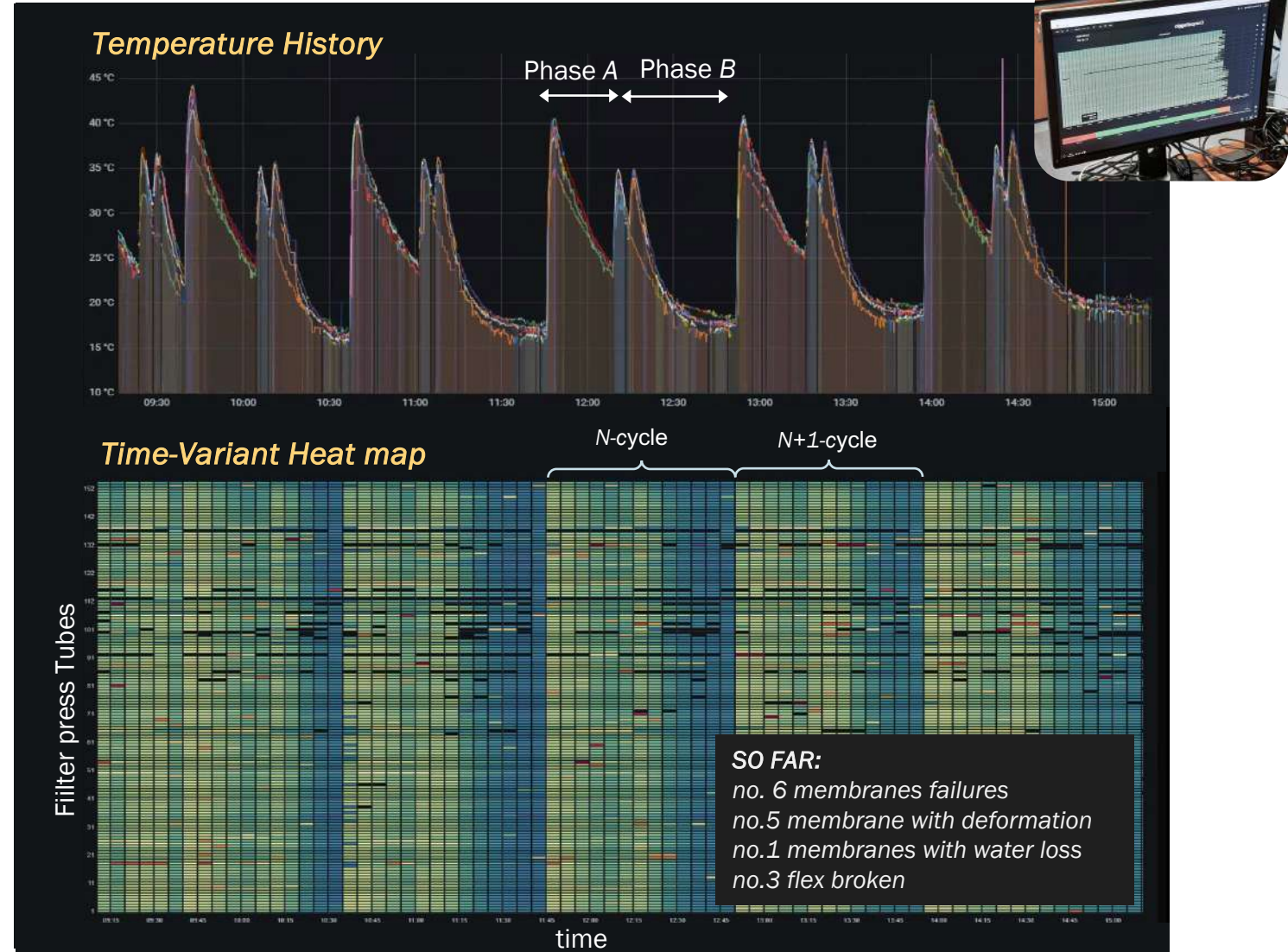

# Oil&Gas Piperack monitoring

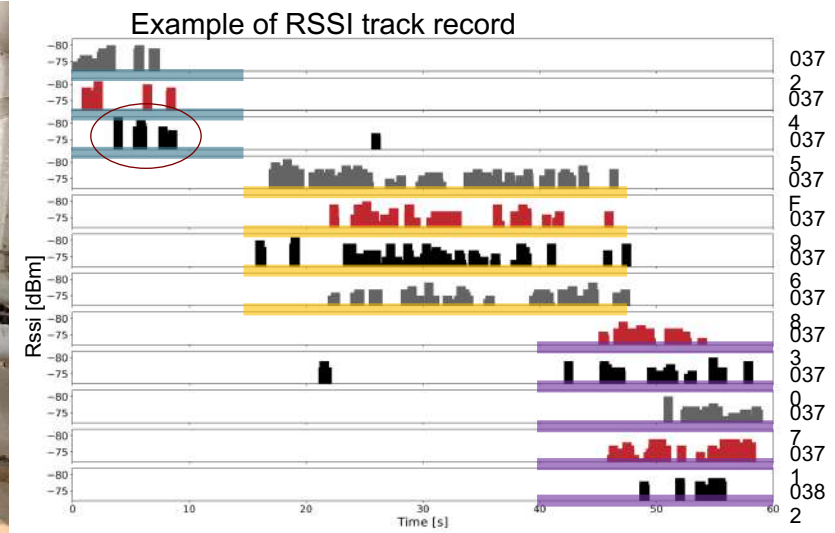
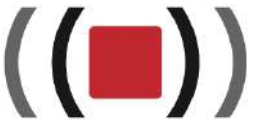

# Switchgears and Electrical Equipments

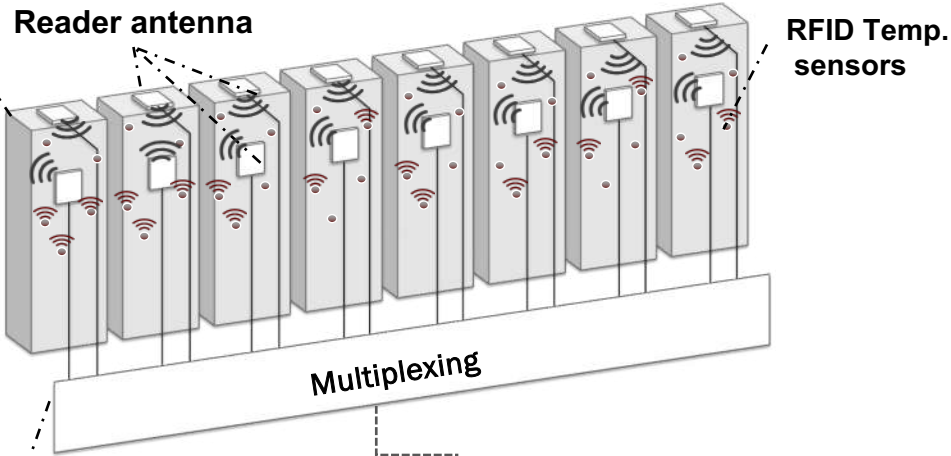
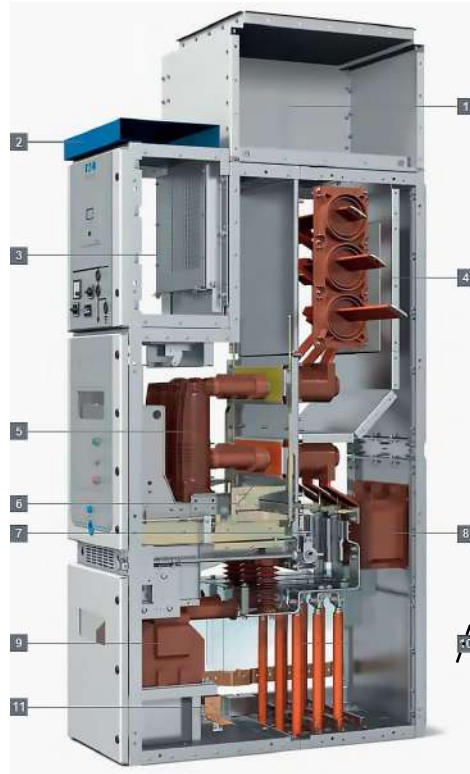

## RFID Platform for Predictive Maintenance

- ✓ Modular architecture
- ✓ High scalability
- ✓ Easy to tailor to any switchgear model
- ✓ Retrofit solution
- ✓ Integration with Scada and web-services

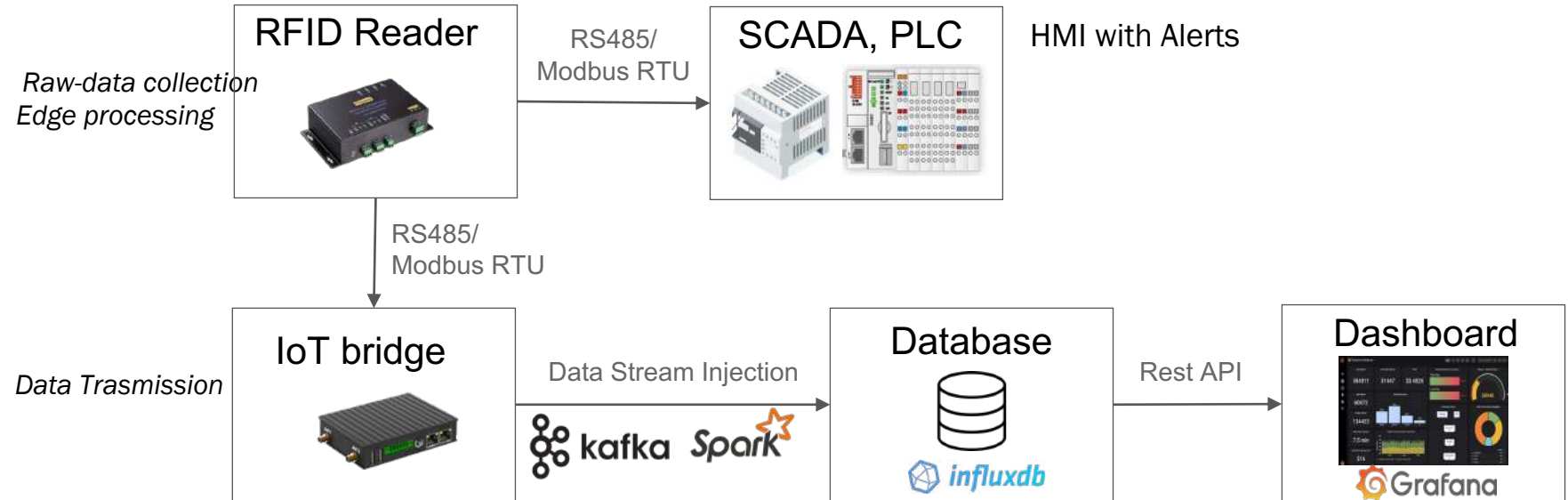

# Switchgear and Electrical Equipment

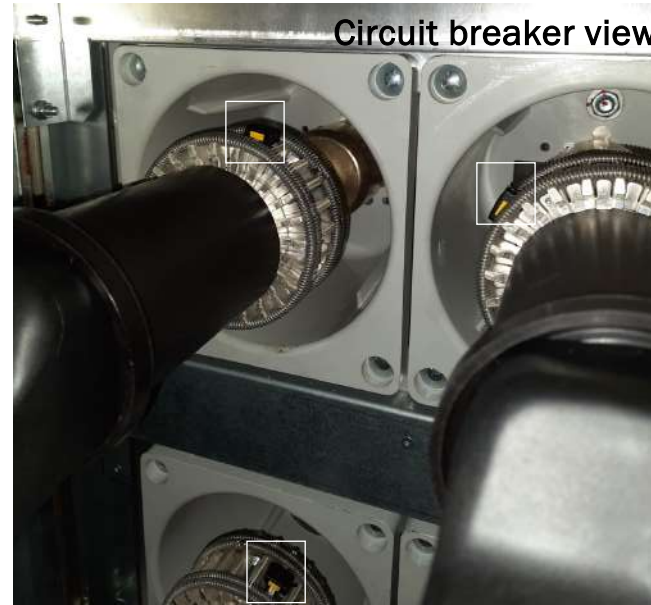
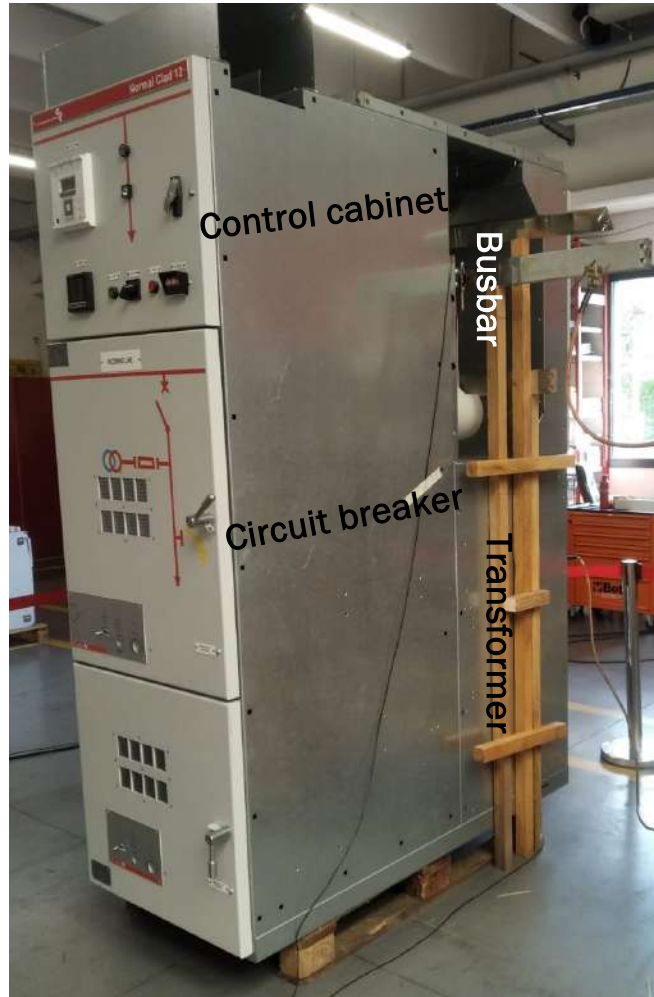

Circuit breaker view



Transformer view



Busbar view



Busbar view



Transformer view



Control cabinet view

- )) Circuit breakers,(plum and contact)
- )) Busbars
- )) Cables

- )) RMU connectors
- )) Transformer,
- )) Electrical Interconnections

# Industrial Manufacturing

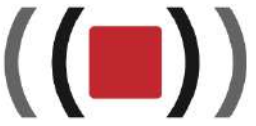

## *Curing of Conveyor Belt*

### The problem

Measuring the temperature “*from the inside*” during the vulcanization process of rubber conveyor

### Challenges

- )) Embedding into layered rubber with carbon filler
- )) High temperature, pressure, mechanical stress
- )) Readability with metal shielding/reflectors

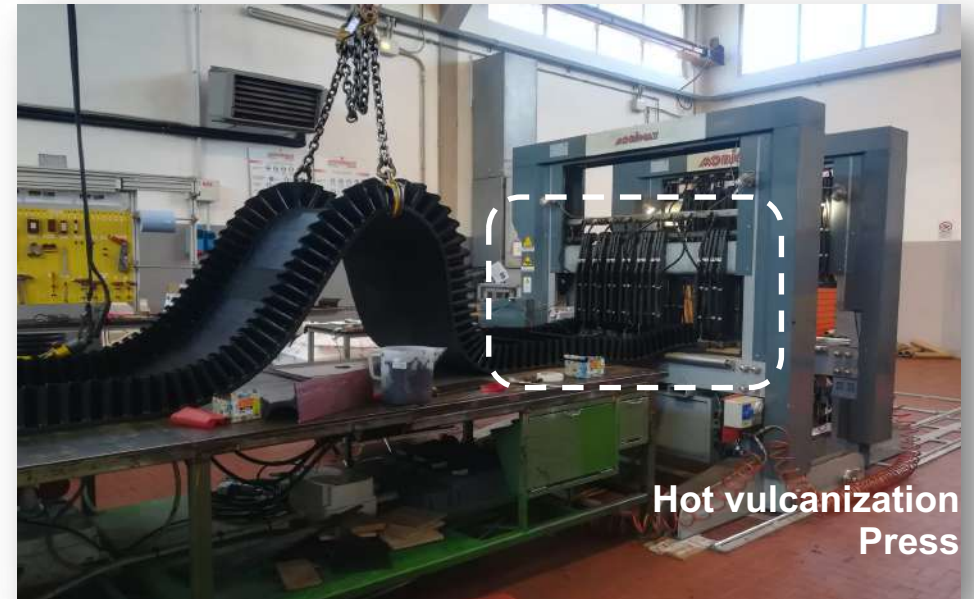

Hot vulcanization  
Press

# Curing of Conveyor Belt

*On-site Installation*

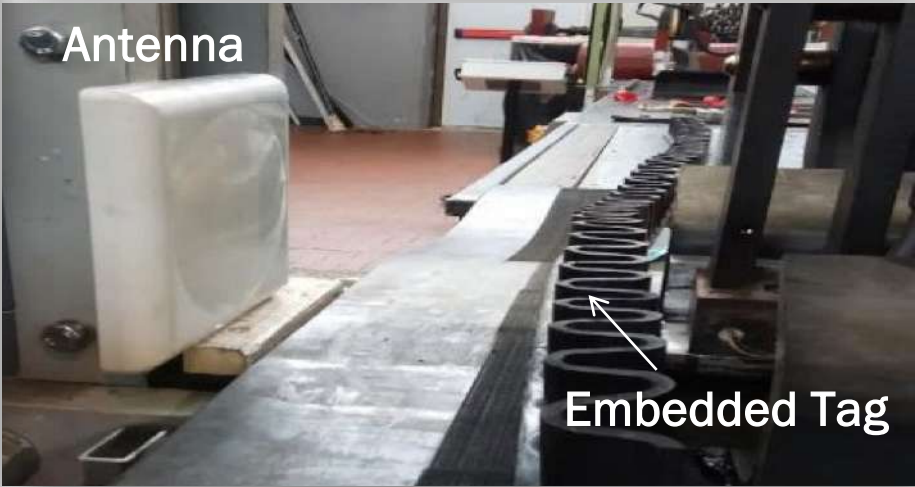
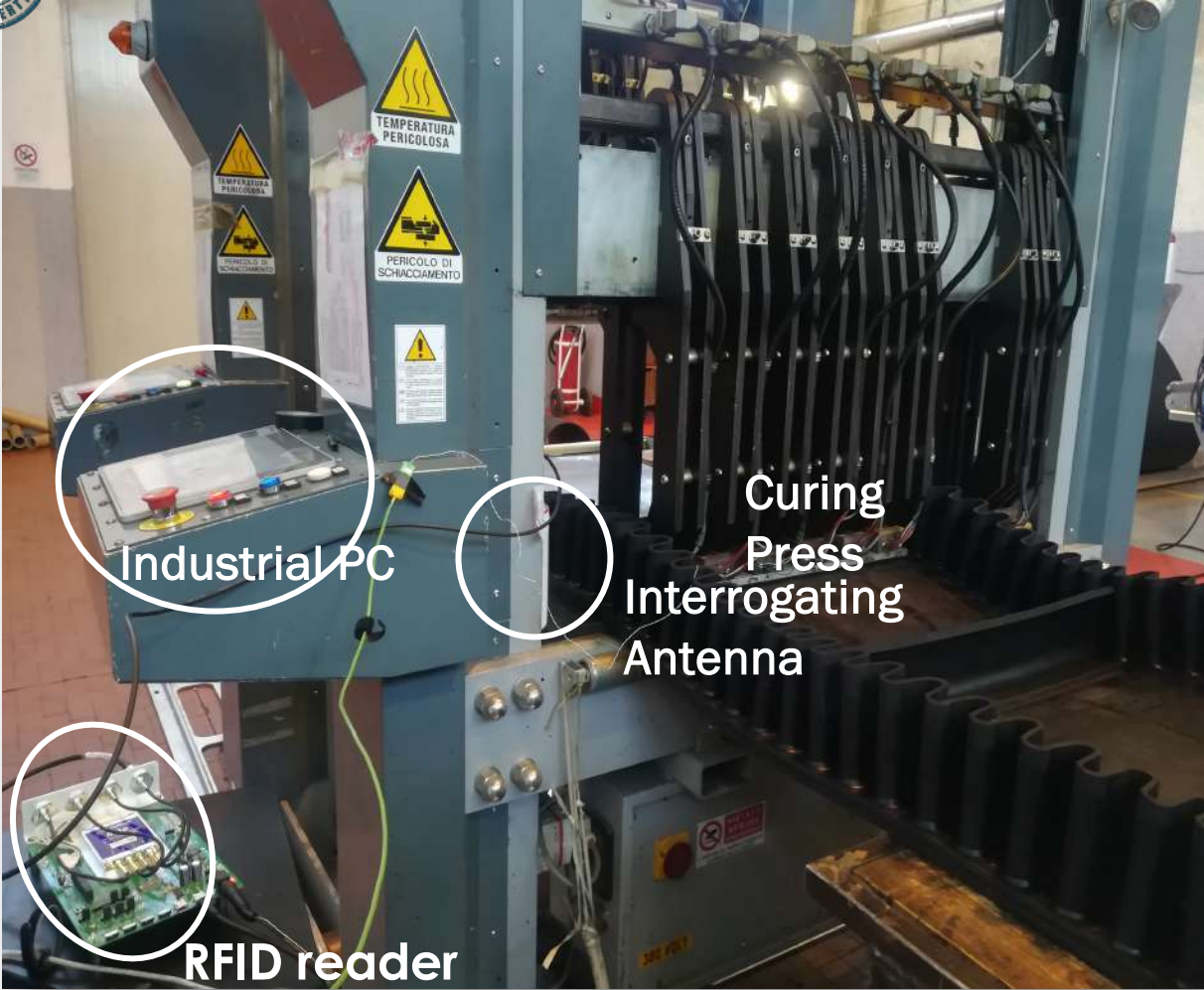

**Retrofitting the existing machinery**



# Adaptive Curing of Conveyor Belt



Physical-Digital-Physical (DPD) loop

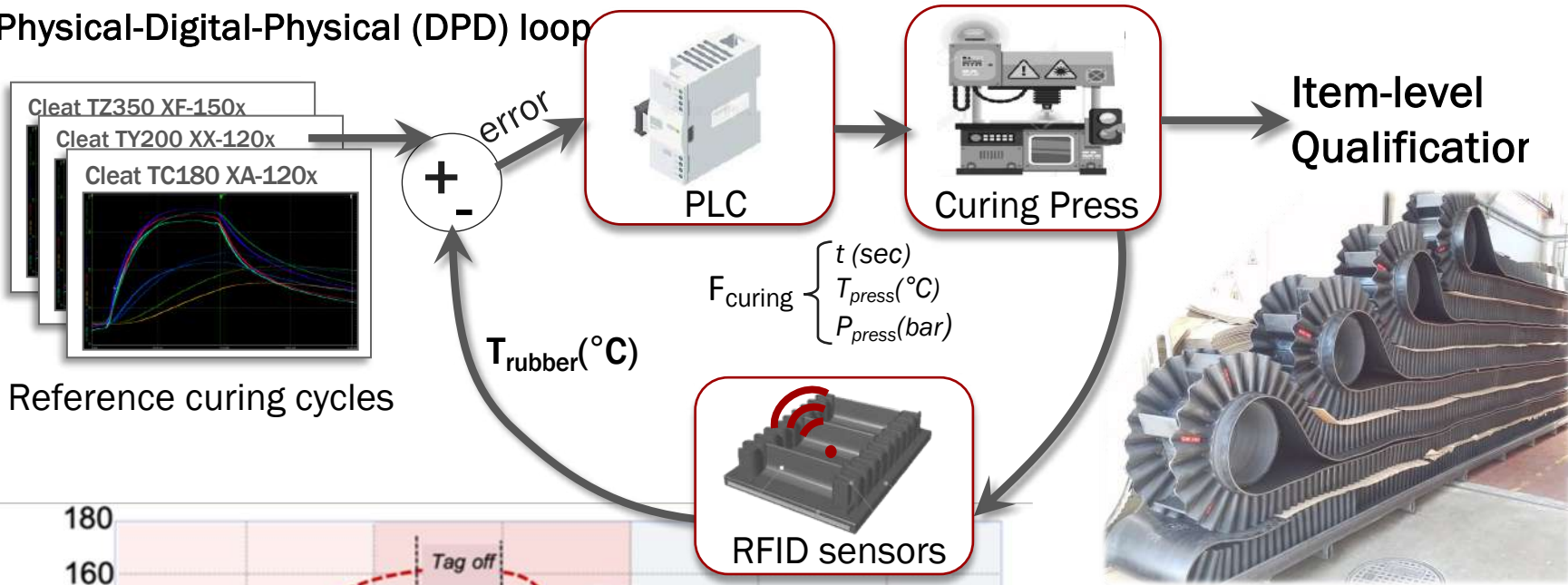

Reference curing cycles

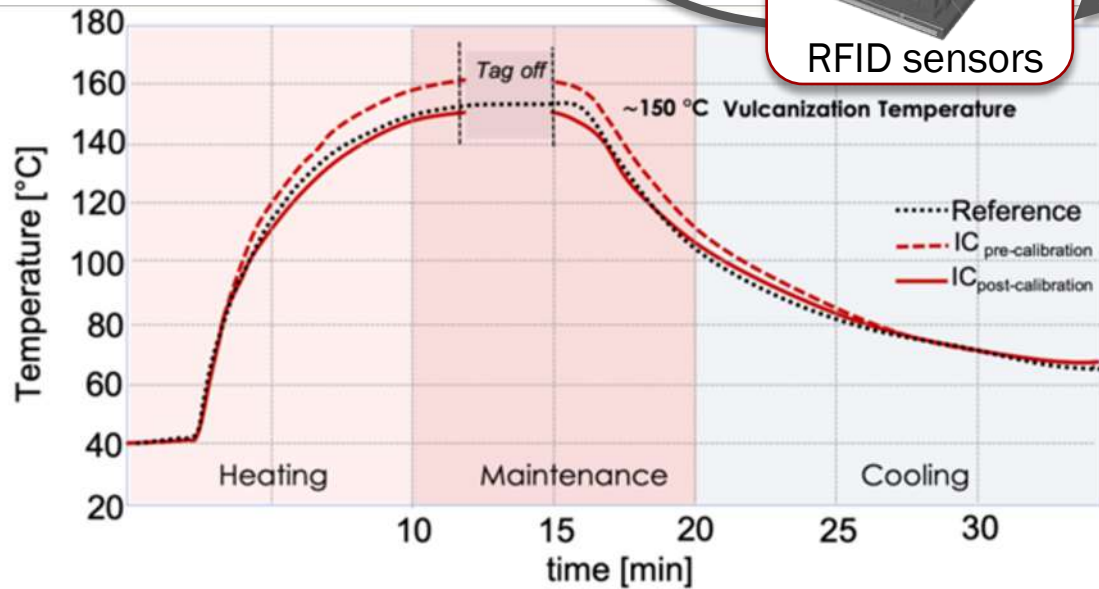

*The object itself  
"tell" the machinery  
how to optimize its  
production process*

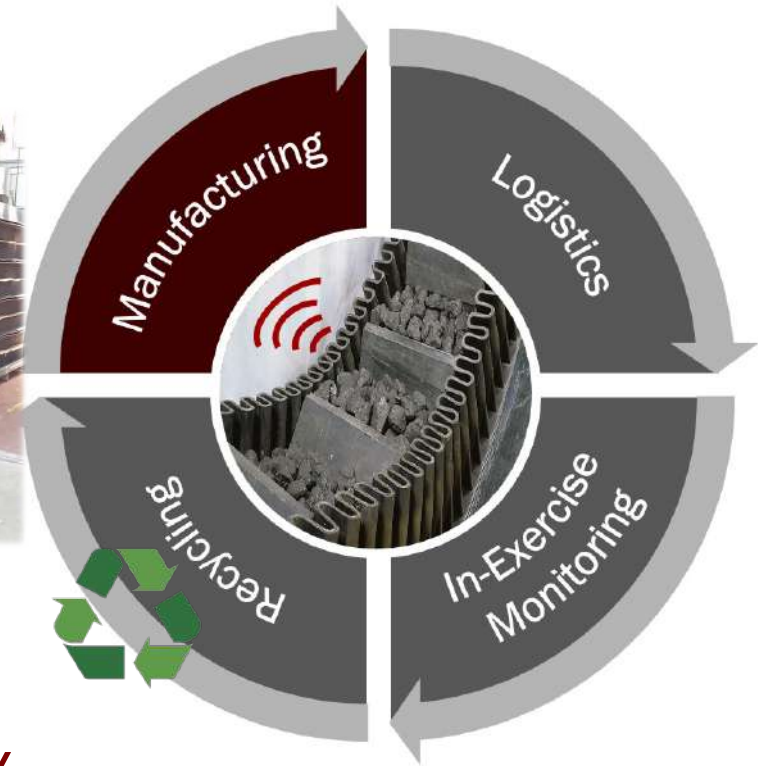

Embedded RFID tag for monitoring the entire product lifecycle

# Rotating blades in paper industry



**Objective:** Wireless Monitoring the temperature of rotating metal blades for wear modelling and **predictive maintenance** of machinery in paper manufacturing

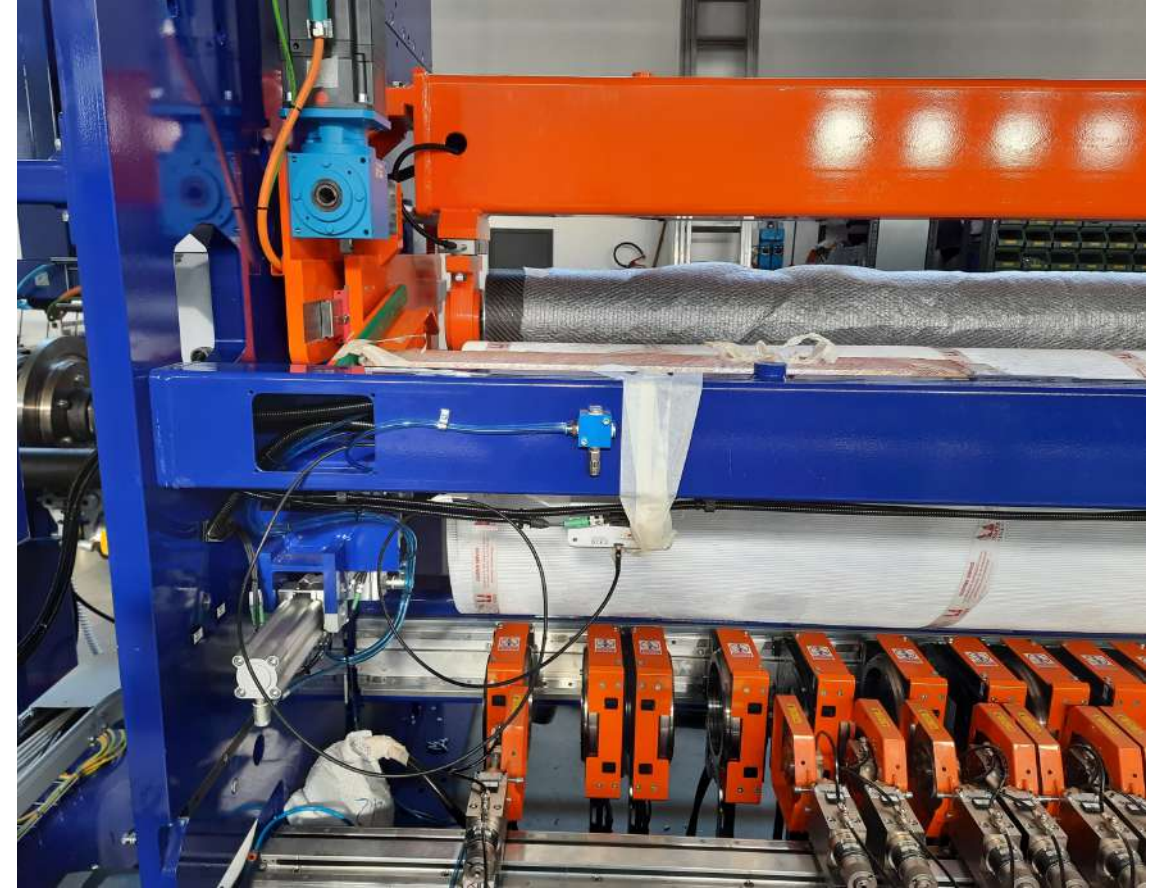

## CHALLENGES

- High-rotating speed
- Fixing methods
- Numbers of target points (>50)
- Radio-coverage of large machineries (> 10 m)
- Harsh EM ambient (metals ,paper dust, vapours)
- Retrofitting

# Rotating blades in paper industry

*Test on Bench*

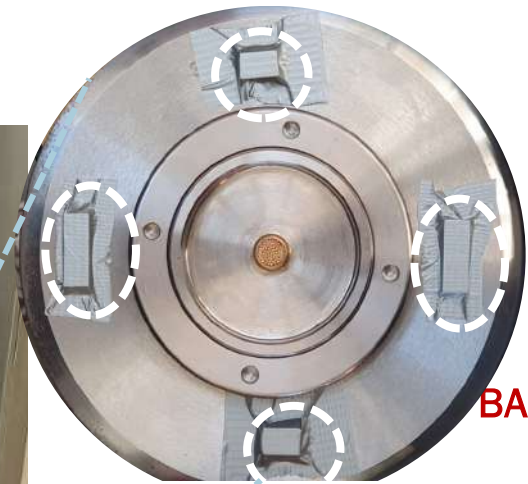
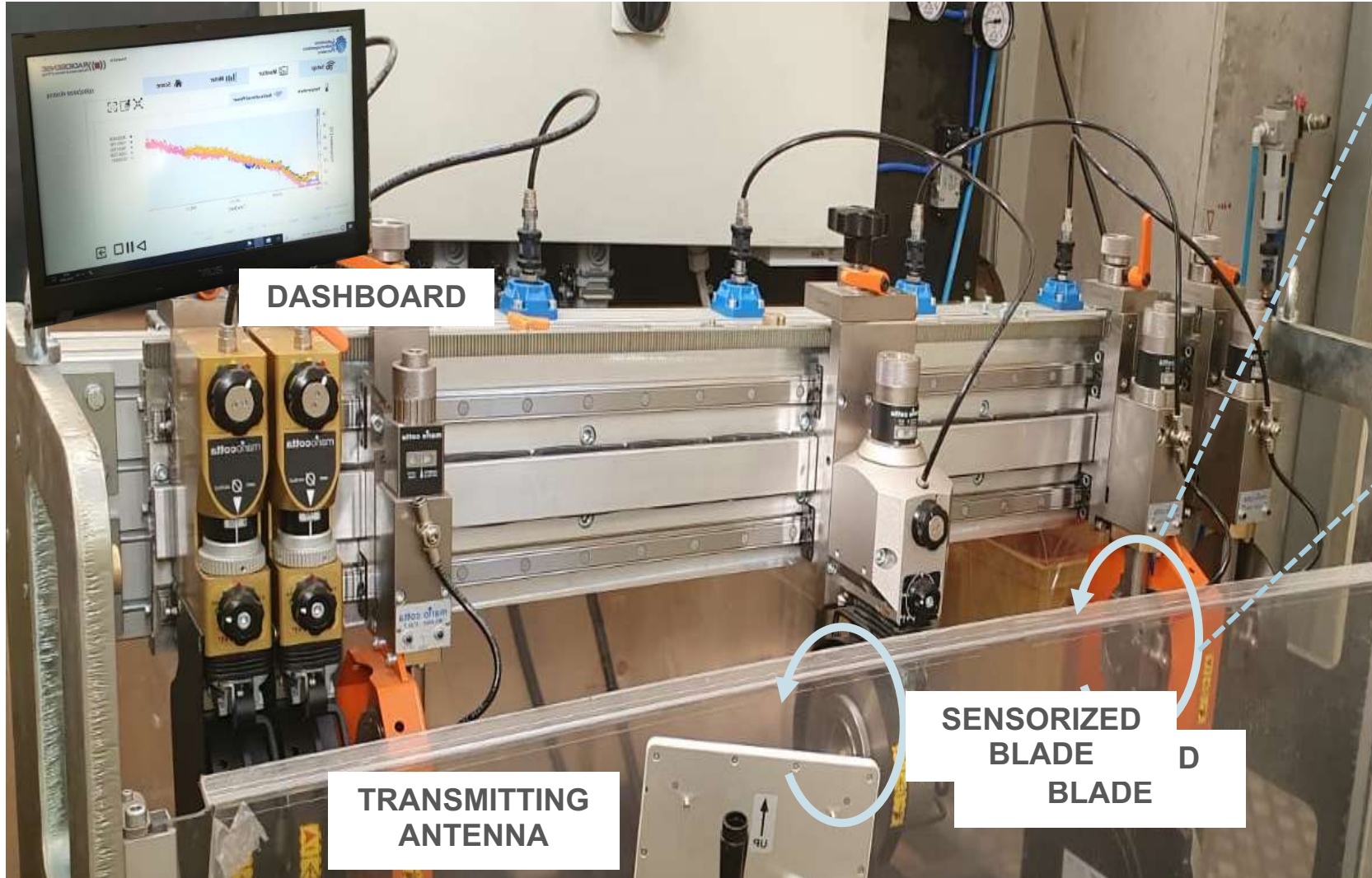
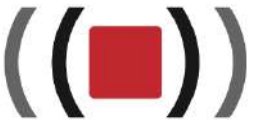

**MULTIPLE  
BATTERY-LESS  
SENSORS**

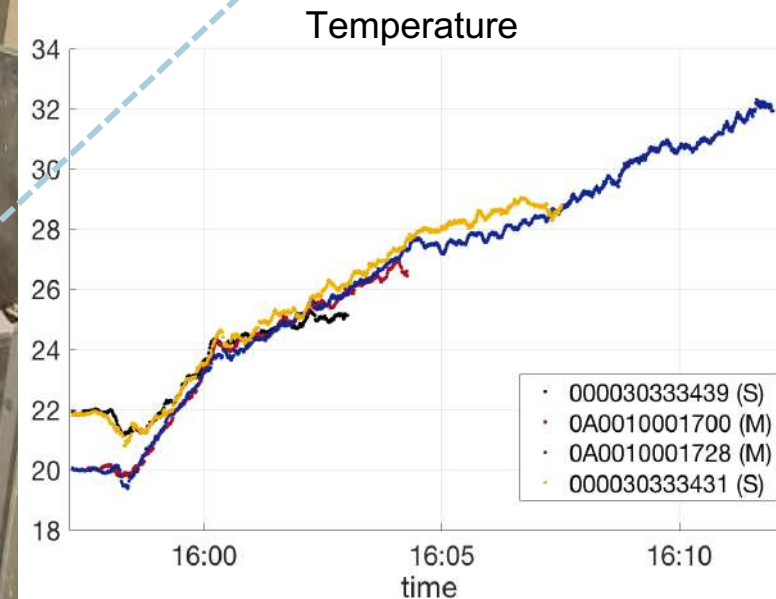

→ Wireless link up to **3000 rpm**



**HEALTHCARE**



# Cyber Implantable devices

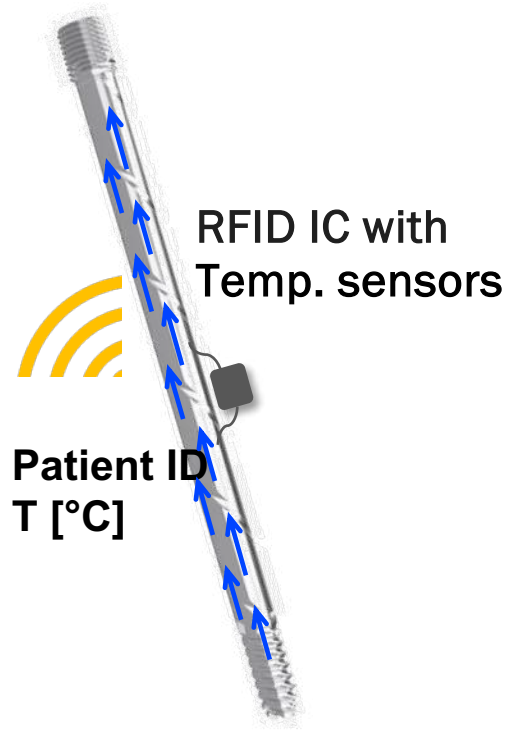
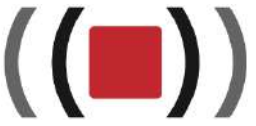

Leveraging o EM know-how on  
Structural antennas

## «Antennifying»

(def. )Turning a metal beam into a device able to talk to a transmitter *outside the body*

## CHALLENGES:

- Through-the-body link
- Extreme miniaturization
- Minimal changes of certified device
- Long-term biocompatibility
- Compliance with surgical procedure
- Medical-grade accuracy
- Manufacturable

# Orthopedic fixation



## MULTIPHYSICS Electromagnetics & Mechanics

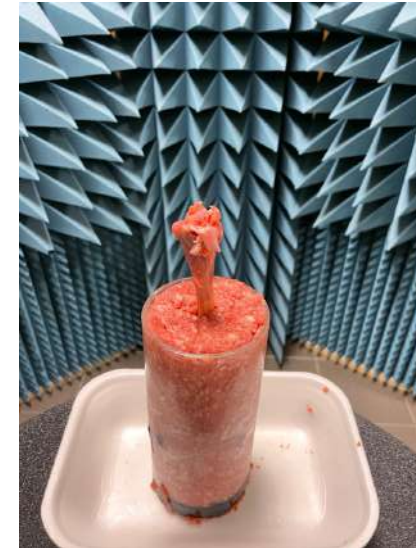
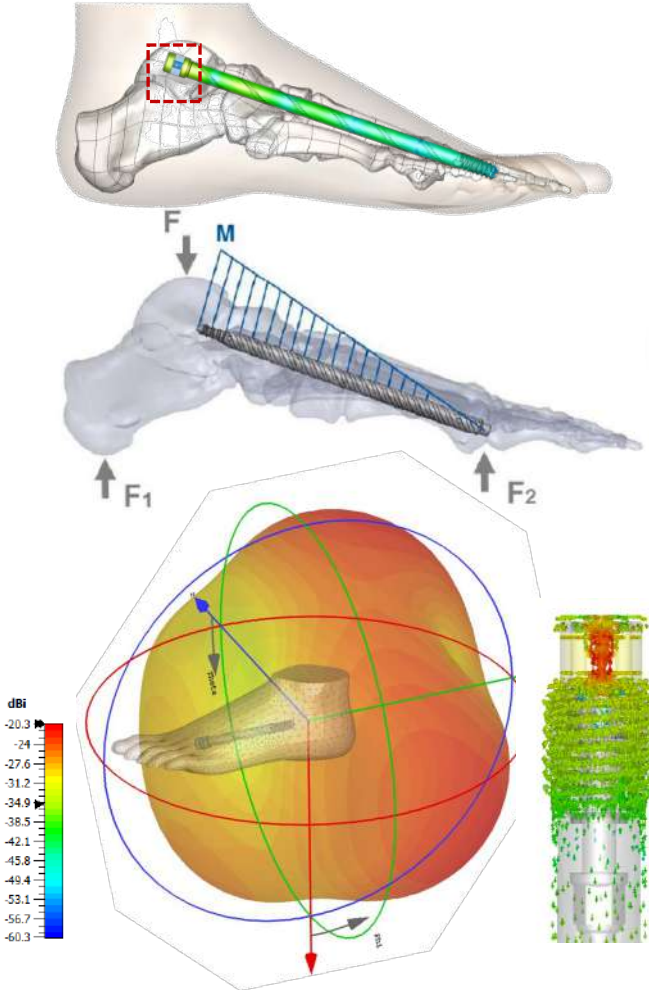

**Add-on Solution**  
No modification of implant  
Adaptable for all beam sizes  
Extremely miniaturized

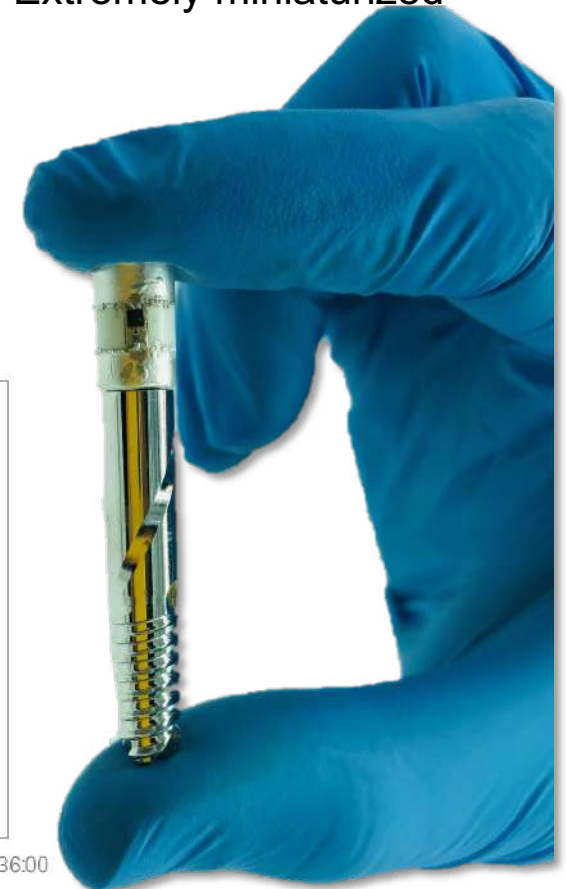
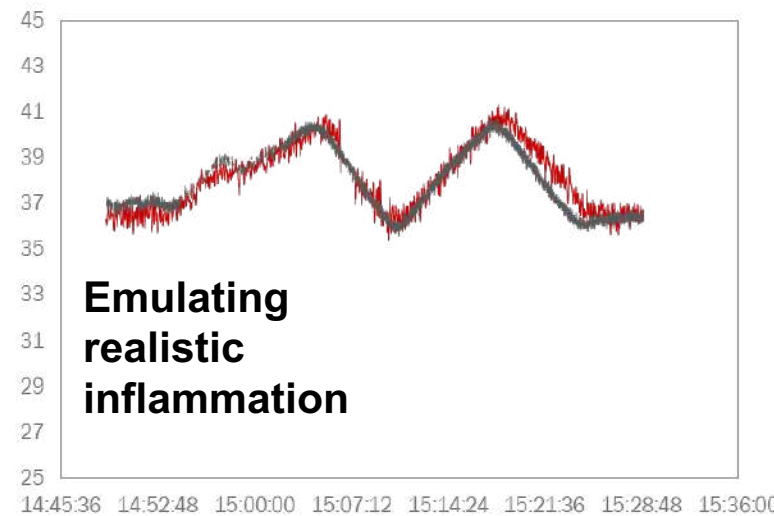

# Innovation Timeline

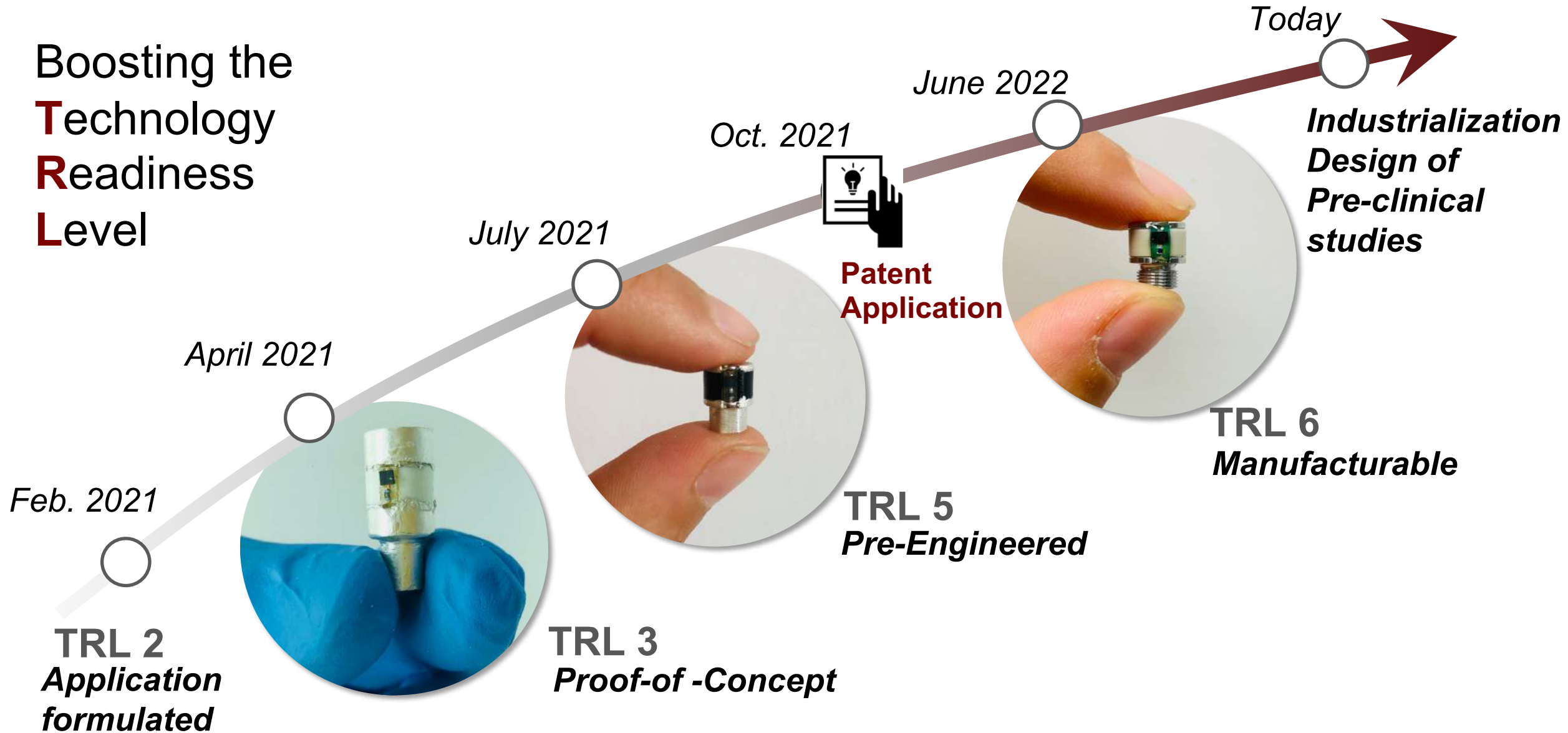
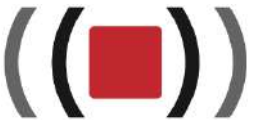

# Pharmaceuticals



Temperature and humidity impacts on drugs quality, effectiveness and safety (pharmaceuticals stability, microbial growth, dissolution....)

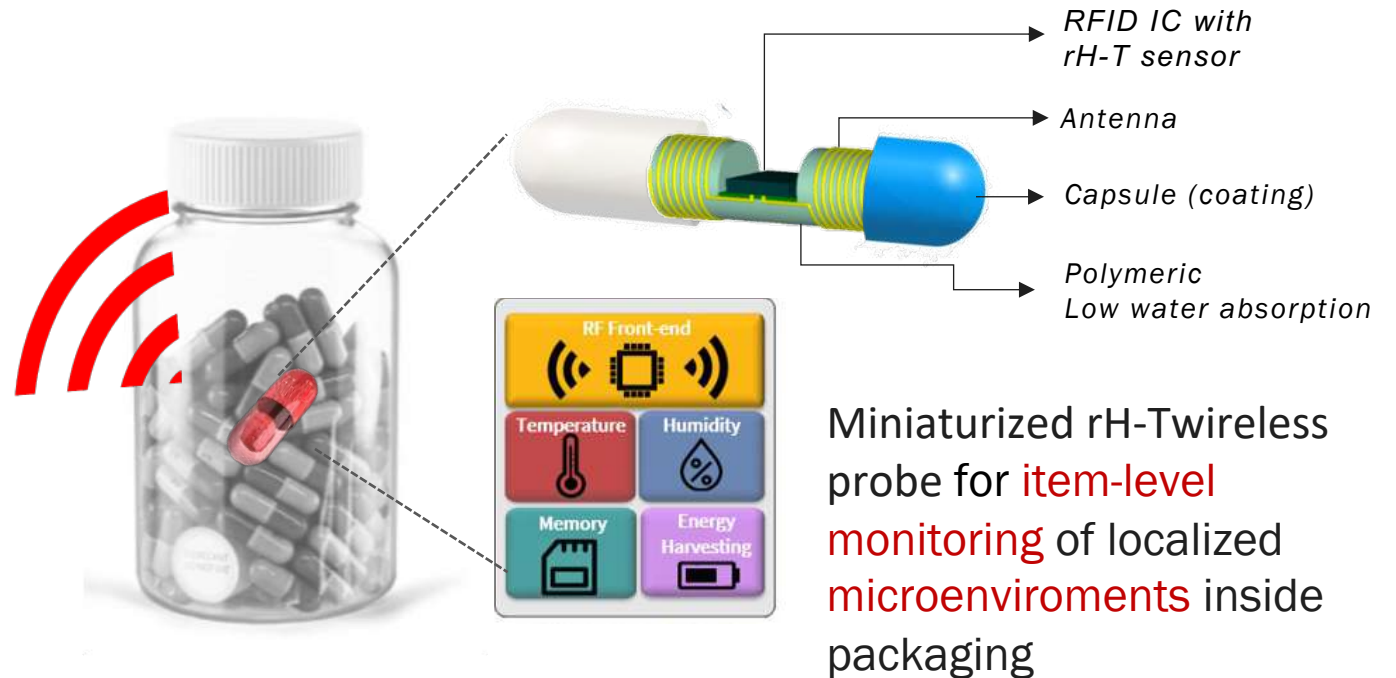

- Stability studies, R&D tool
- manufacturing/ Industry 4.0

## CHALLENGES:

- Extreme Miniaturization
- Multi-parametric battery-less sensing
- Disposable (hence low-cost)
- Materials (low water absorption )
- Variable conditions (pills, orientation, packaging)
- Accuracy, reliability (<5% rH) "Pharma"-grade





# Pharmaceuticals

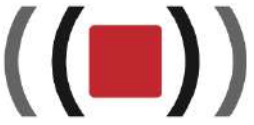

## The Radio Pill

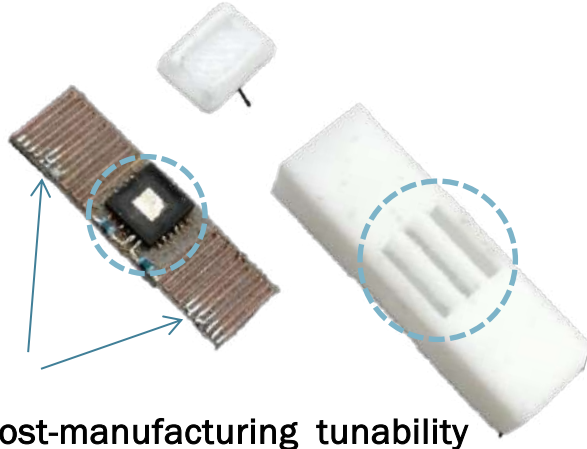

Post-manufacturing tunability  
Single probe for multiples fillings  
(liquids, powers, tablets...)

Size ~ 15x7x5mm  
Weight < 5g  
water absorption ~ 2.2mg

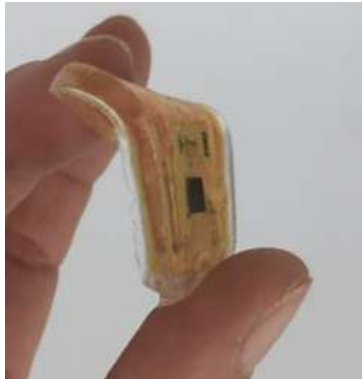

1<sup>st</sup> PoC (complex!!)



3D Helix

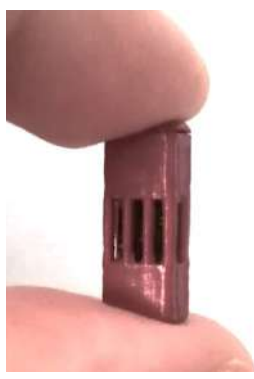

2D Printed MLA

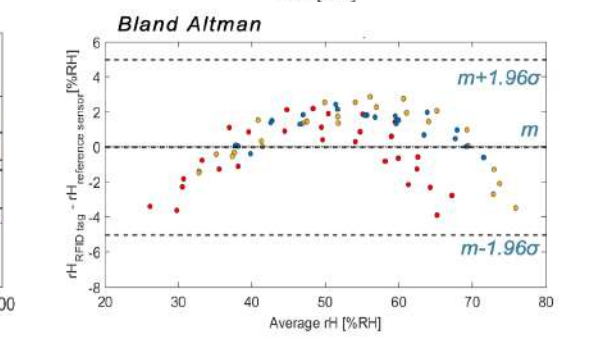
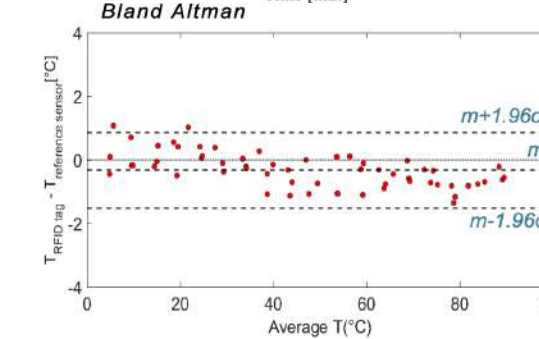
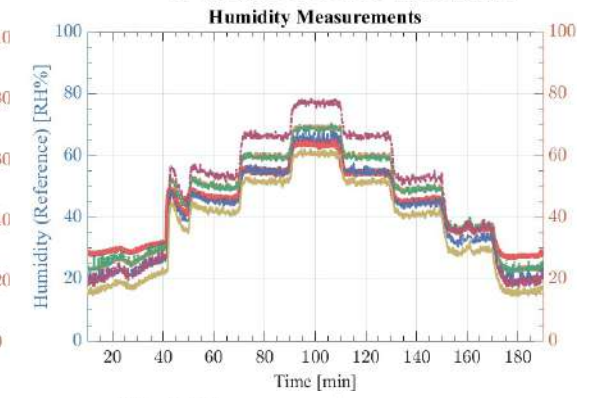
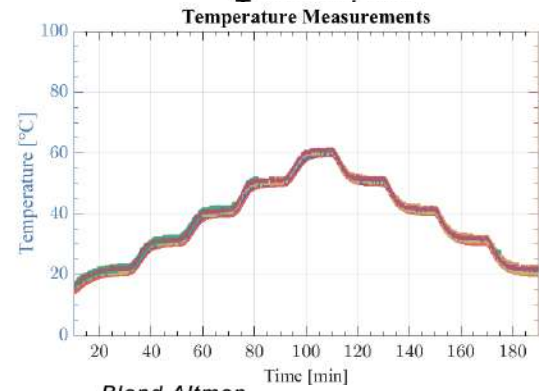
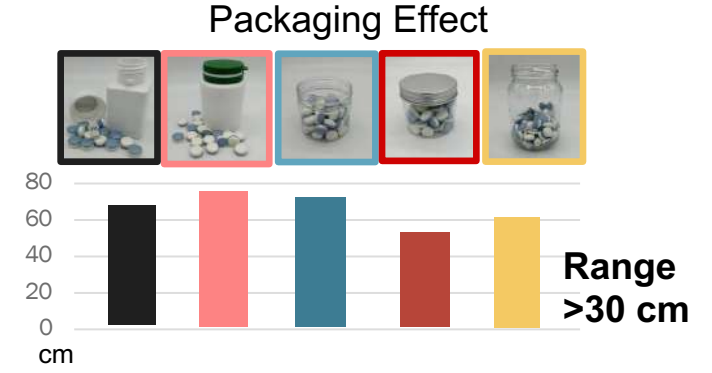
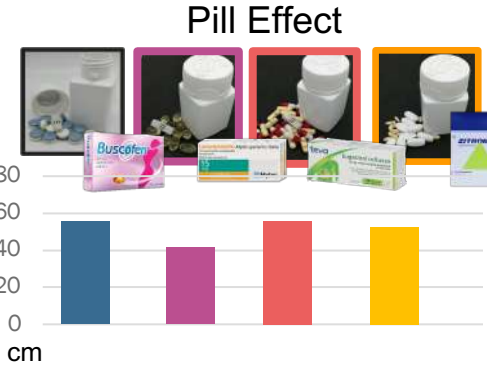

Temp. Accuracy ± 1 °C

rH Accuracy ± 5% (± 3% sub.range)



ACIDS ONLY

IMMABLE ACIDS  
DARD SOLVENTS

SSS  
SSS

FUJITSU

ASAP EQUIPMENT

Pfizer





**Mondo Fisico**

**Mondo Digitale**



**FOOD**



# Tropical Fruit Ripening



RF query  
(freq power)

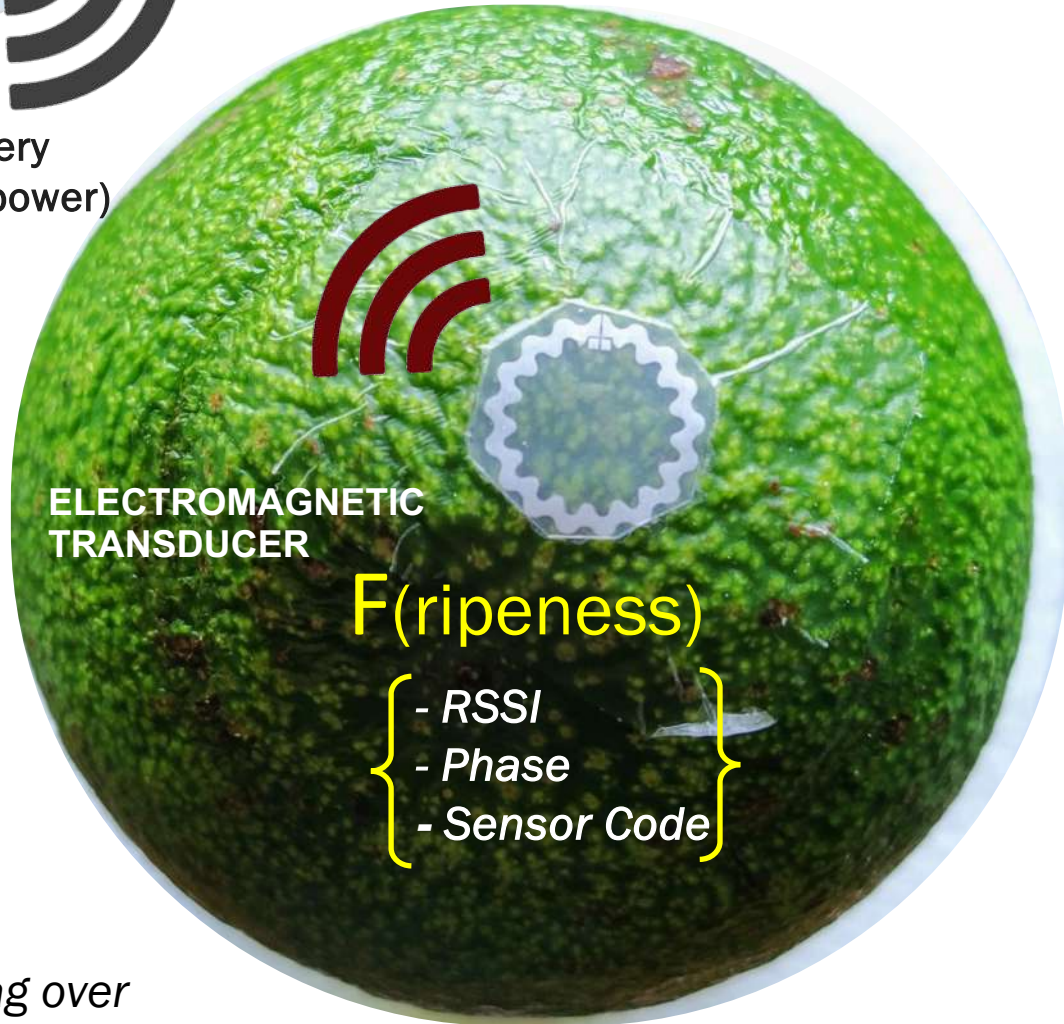

ELECTROMAGNETIC  
TRANSDUCER

$F(\text{ripeness})$

- RSSI
- Phase
- Sensor Code

Tag over  
the peel



## Antenna-as-a-Sensor

- sensor-less
- non-destructive
- passive

Tag on/in Skin  
Packaging



# ELECTROMAGNETIC FINGERPRINT



COMPLEX - NOT  
MONOTONIC -  
PHENOMENON

Q. Is my avocado  
ready to be  
distributed?



MACHINE  
LEARNING

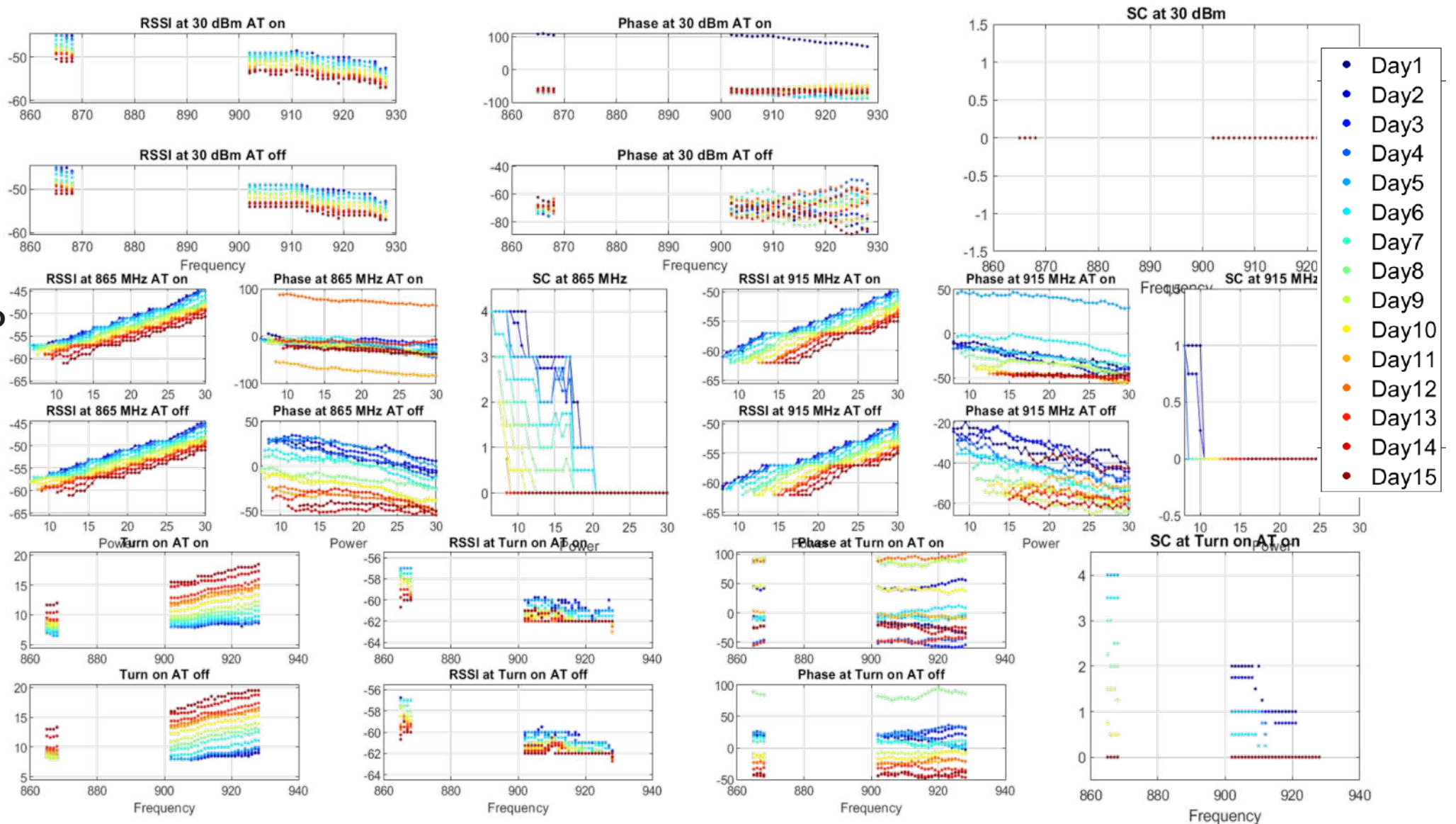



# Fruit ripening chamber



PHYSICAL LAYER



APPLICATION LAYER (WEB)

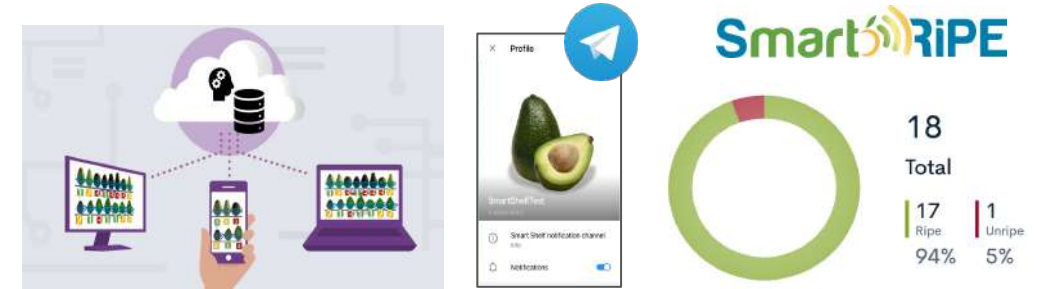

Enforced Support Vector Machine

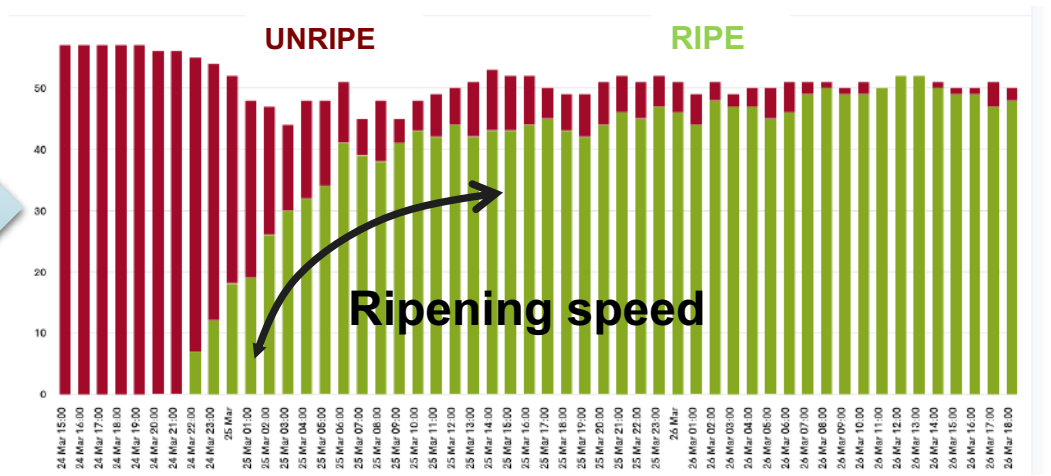

Prediction Accuracy >85% (ripening onset)

> 30 campaigns; >4500 fruits; > 31k predictions

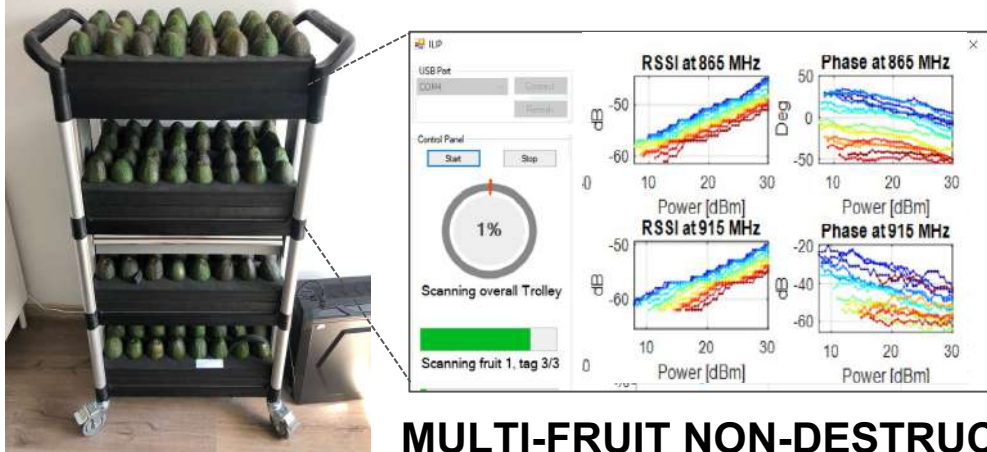

MULTI-FRUIT NON-DESTRUCTIVE RF SYSTEM



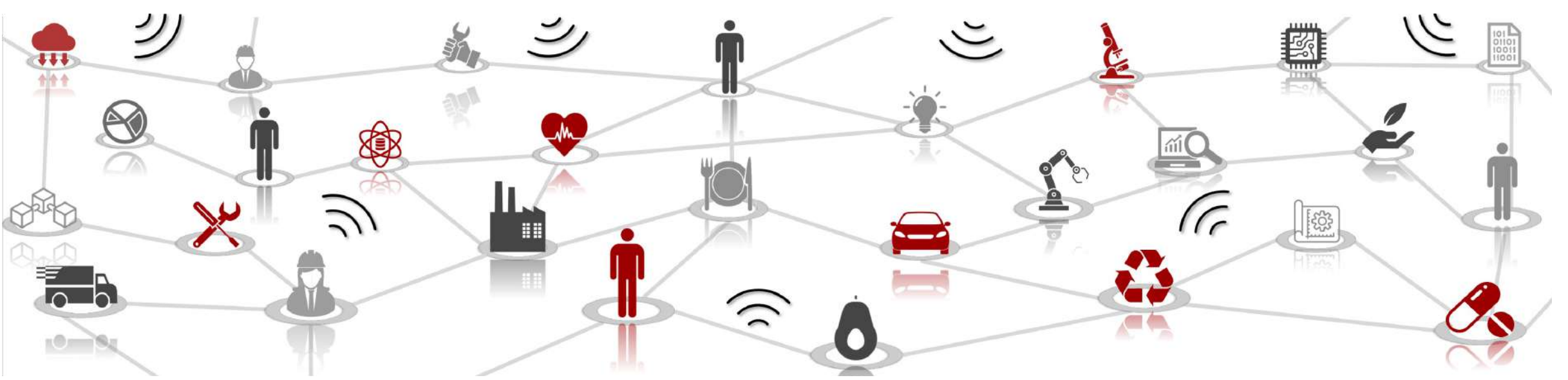

[www.radio6ense.com](http://www.radio6ense.com)

# **RADIO6ENSE**

The last meter of Internet of Things

*A Spin-off of the University of Rome Tor Vergata*

Ref.

Dr. Sara Amendola

Dr. Cecilia Occhiuzzi

[amendola@radio6ense.com](mailto:amendola@radio6ense.com)

[occhiuzzi@radio6ense.com](mailto:occhiuzzi@radio6ense.com)

0672597458

0672597458